

# DDR3L:512MBytes

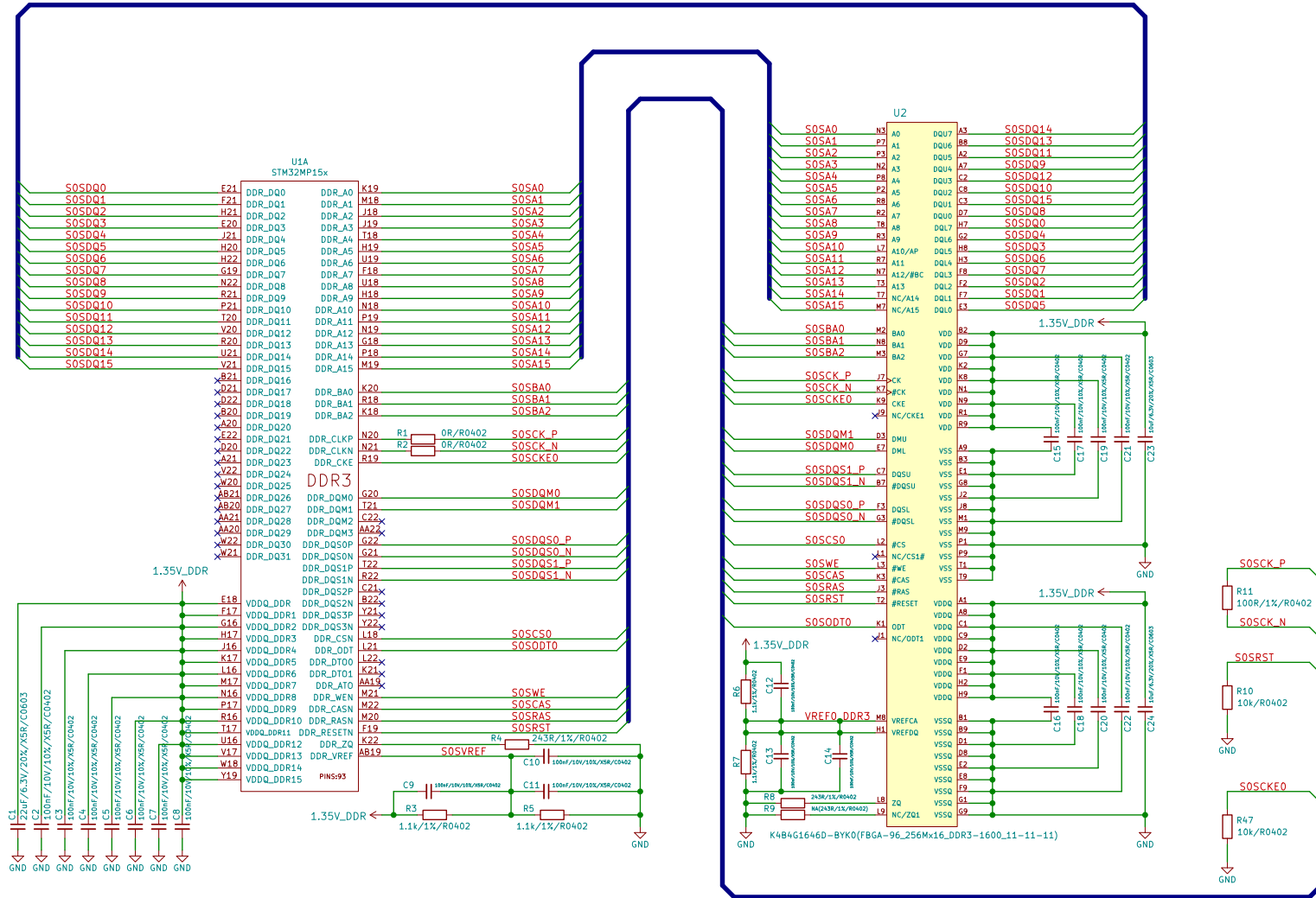

**Note:**

=====

We have used a number of fully compatible, but different DDR3 memories due to supply unavailability. In such cases the memory part name in the schematic might remain outdated. It is recommended to always refer to the exact memory name printed on the component itself.









# Audio

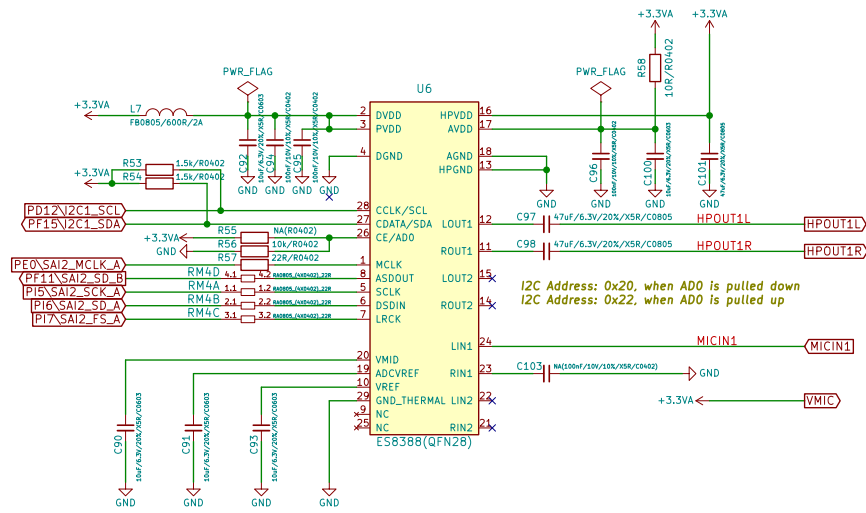

<https://www.olimex.com/>  
**OLIMEX LTD, Bulgaria**  
 Sheet: /Audio/  
 File: Audio.sch

**Title: STMP1-SOM**

Size: A3 | Date: 2024-04-17  
 KiCad E.D.A. kicad 5.1.4-e60b26684ubuntu18.04.1

Rev: E  
 Id: 5/5