

Input Connectors

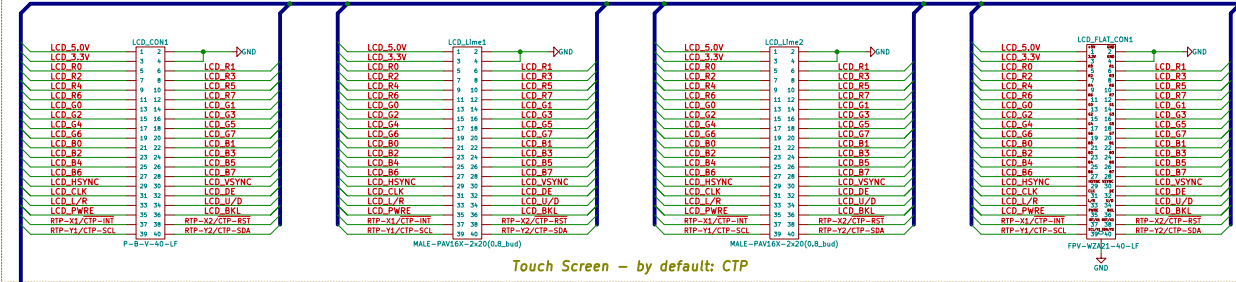

Touch Screen – by default: CTP

Power Supply Control

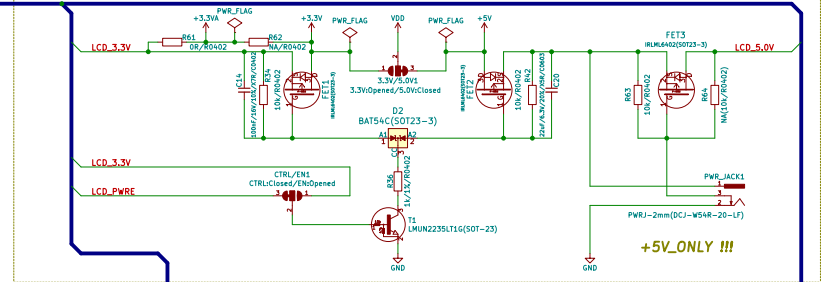

LCD-4.3in

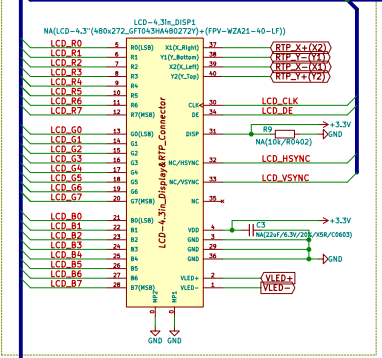

LCD-5in

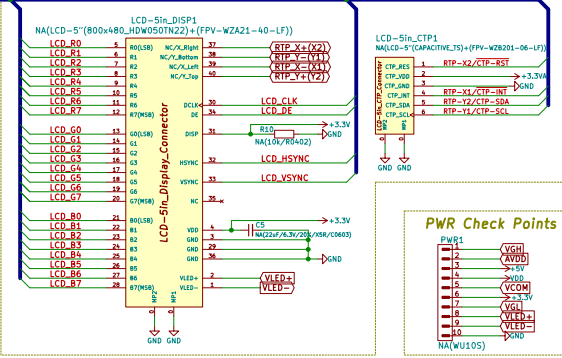

Resistive Touch Screen Controller

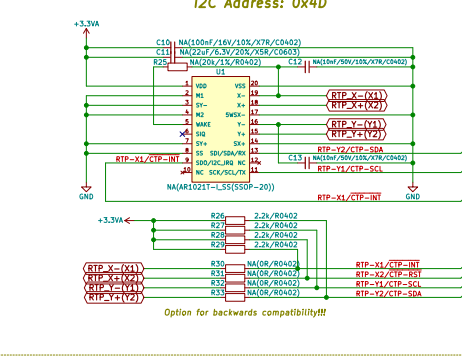

Backlight

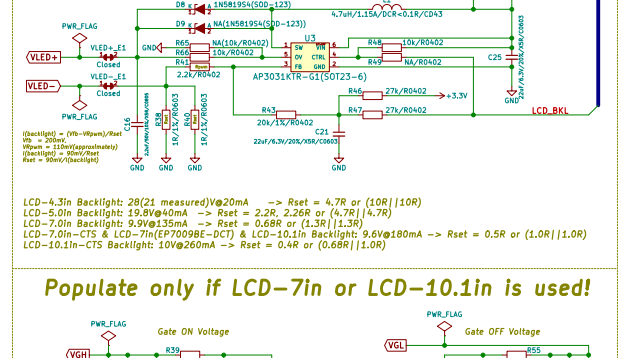

LCD-7in

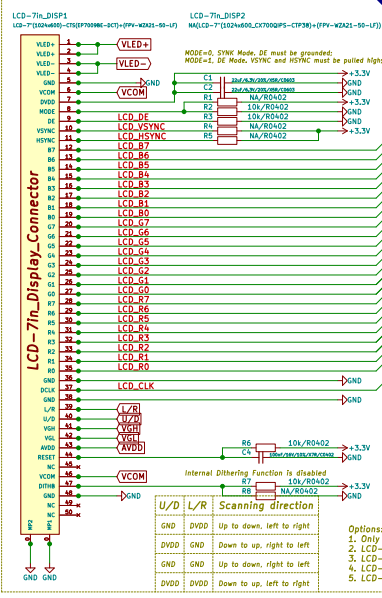

Common

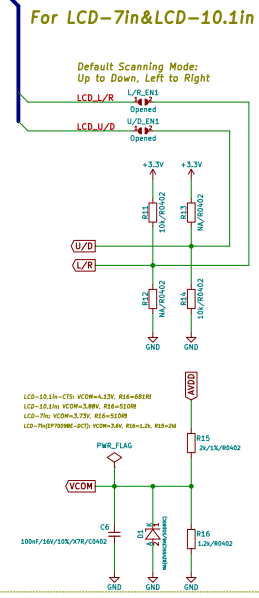

LCD-10.1in

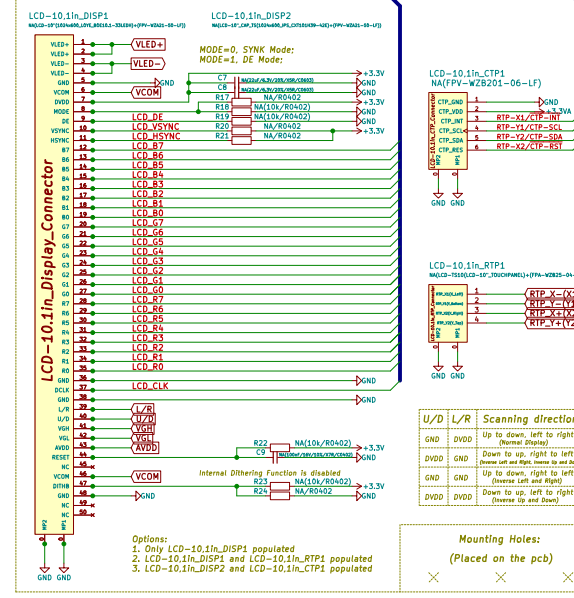

Populate only if LCD-7in or LCD-10.1in is used!

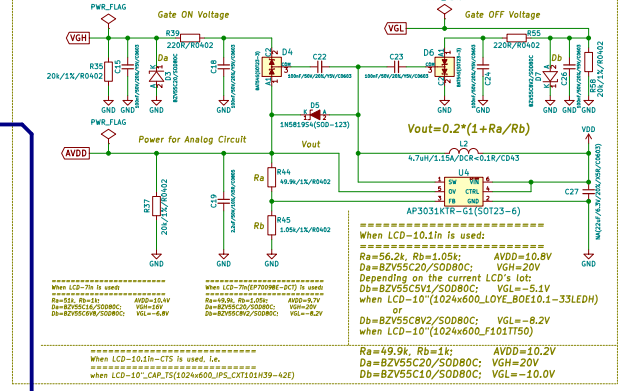

LCD Identification

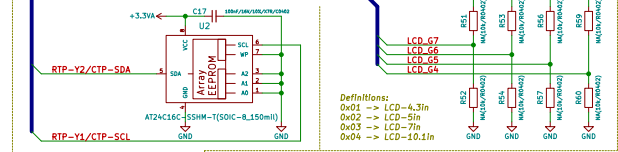

EEPROM

I2C Address: 0xA0

OLIMEX LTD, Bulgaria

File: LCD-DRIVER_Rev_E.sch

Title: LCD-DRIVER

Size: 42 Bytes

Rev: E

Fiducials:

FID1 Fiducial

FID2 Fiducial

FID3 Fiducial

FID4 Fiducial