



**PRELIMINARY  
SPECIFICATION  
FOR  
LCD MODULE**

**ORDER NO : CL010-4042-01**

**MODULE NO.: CL010-4042-E-RH**

**DOC.REVISION A00**

**Customer Approval:**

--

	NAME	SIGNATURE	DATE
PREPARED BY	KOWK SHING FU		16 SEP 2010
CHECKED BY	FU SZE HOI		17 SEP 2010
APPROVED BY	FU SZE HOI		17 SEP 2010



**DOCUMENT REVISION HISTORY**

<b>Version</b>	<b>DATE</b>	<b>DESCRIPTION</b>	<b>CHANGED BY</b>
A00	16 SEP 2010	First issue	



<b>Dimensional Outline</b>	<b>1</b>
<b>Functions &amp; Features</b>	<b>2</b>
<b>Mechanical Specifications</b>	<b>2</b>
<b>Block Diagram</b>	<b>3</b>
<b>Pin Description</b>	<b>3</b>
<b>Maximum Absolute Limit</b>	<b>4</b>
<b>Electrical Characteristics</b>	<b>4, 5, 6</b>
<b>LCD Mapping Specifications</b>	<b>7</b>
<b>Quality Specifications</b>	<b>8-16</b>



1. DIMENSIONAL OUTLINE

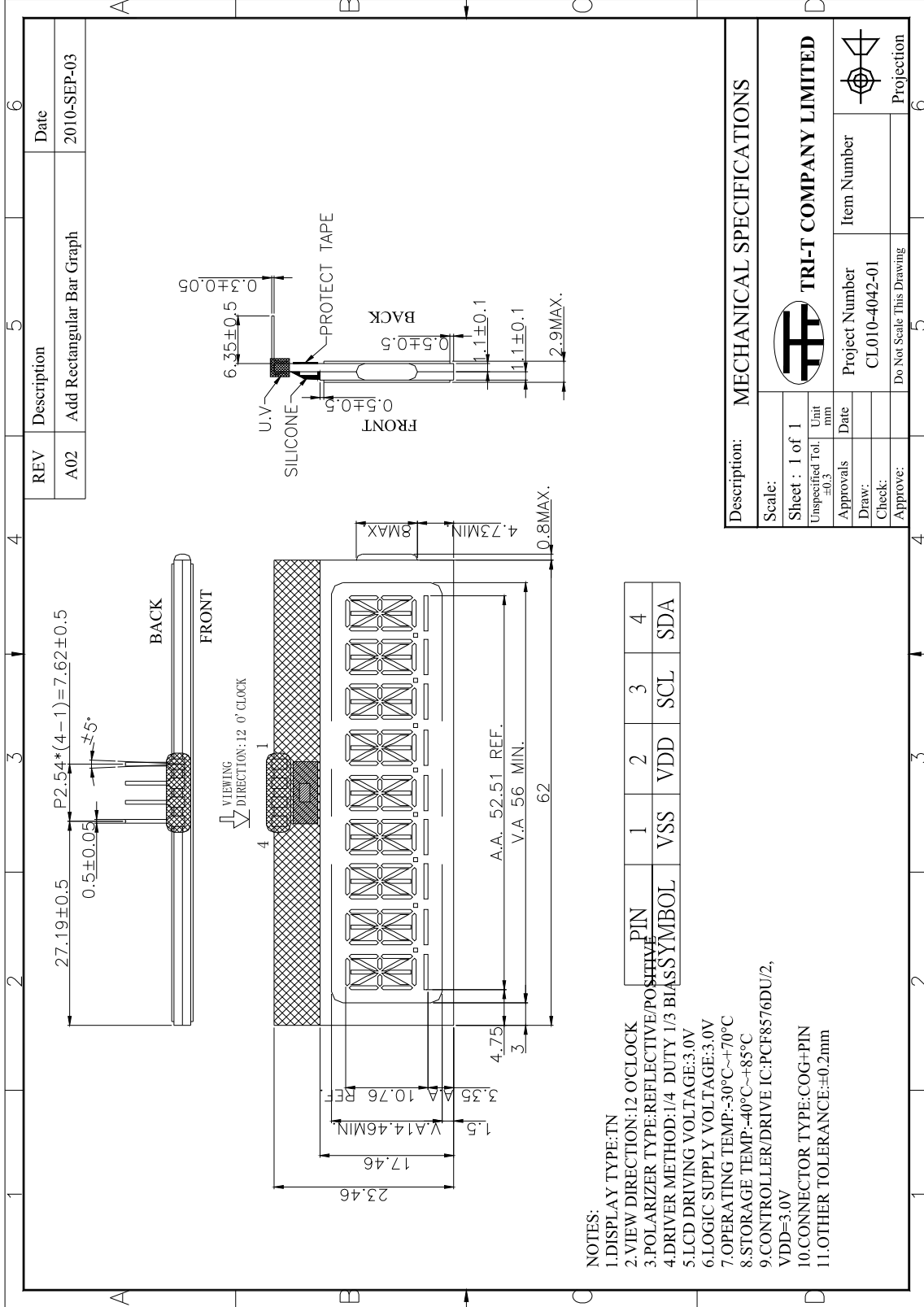

- NOTES:
- 1.DISPLAY TYPE:TN
  - 2.VIEW DIRECTION:12 O'CLOCK
  - 3.POLARIZER TYPE:REFLECTIVE/POSITIVE
  - 4.DRIVER METHOD:1/4 DUTY 1/3 BIAS
  - 5.LCD DRIVING VOLTAGE:3.0V
  - 6.LOGIC SUPPLY VOLTAGE:3.0V
  - 7.OPERATING TEMP:-30°C~+70°C
  - 8.STORAGE TEMP:-40°C~+85°C
  - 9.CONTROLLER/DRIVE IC:PCF8576DU/2, VDD=3.0V
  - 10.CONNECTOR TYPE:COG+PIN
  - 11.OTHER TOLERANCE:±0.2mm

PIN	1	2	3	4
SYMBOL	VSS	VDD	SCL	SDA

Description:		MECHANICAL SPECIFICATIONS	
Scale:	Sheet : 1 of 1	Unit	mm
Unspecified Tol:	±0.3	Date	
Approvals		Item Number	
Draw:		Project Number	CL010-4042-01
Check:		Do Not Scale This Drawing	
Approve:		Projection	

TRI-T COMPANY LIMITED

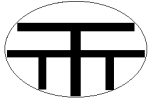

## **2.FUNCTIONS & FEATURES**

2-1. Format	: 14 segment digits + Symbols
2-2. LCD Mode	: TN, Positive, Reflective
2-3. Viewing Direction	: 12 o'clock
2-4. Driving Scheme	: 1/4 duty, 1/3 Bias
2-5. Single Supply Voltage	: Power supply voltage range ( $V_{DD}$ ): 3.0V
2-7. With Metal Pin connector	

## **3.MECHANICAL SPECIFICATIONS**

3-1. Module size	: 62.00mm(L) * 23.46mm(W) * 2.9mm(D) max
3-2. Viewing area	: 52.51mm(L) * 10.76mm(W)



## **4. BLOCK DIAGRAM**

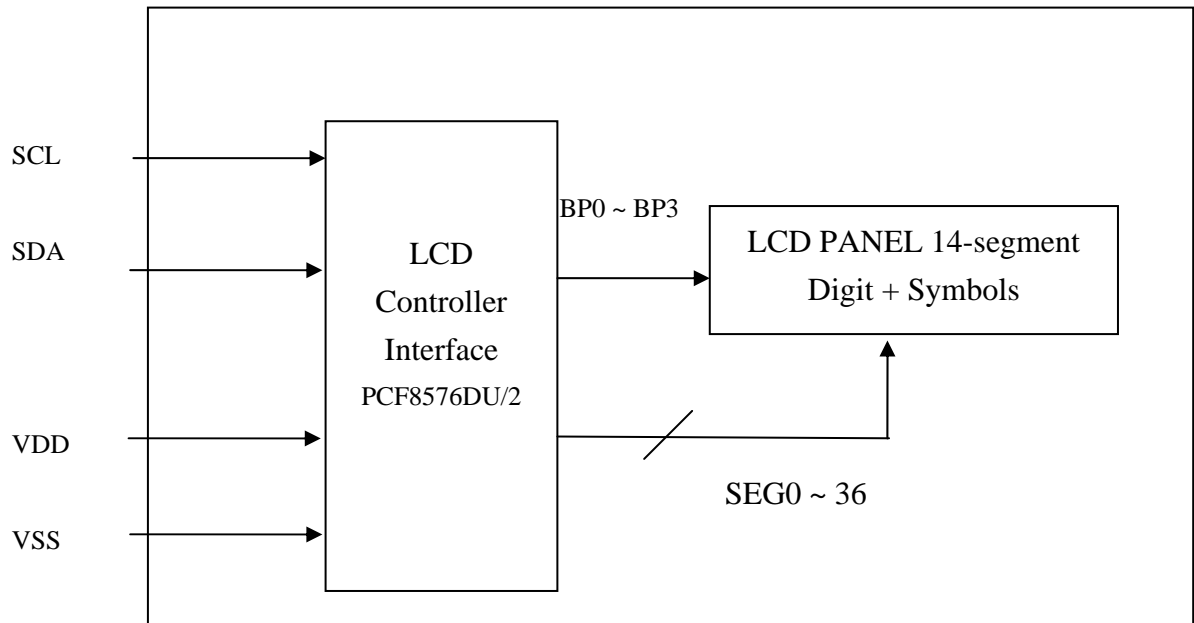

## **5. PIN DESCRIPTION**

1	VSS	Power Supply Ground (0V)
2	VDD	Power Supply (+3.0V)
3	SCL	I2C serial clock input pin
4	SDA	I2C serial data input pin



## 6. MAXIMUM ABSOLUTE LIMIT (T=25°C)

Item	Symbol	Standard value	Unit
Power supply voltage for logic	V <sub>DD</sub>	-0.5~+6.5	V
Input voltage	V <sub>IN</sub>	V <sub>SS</sub> +0.5 ~ V <sub>DD</sub> +0.5	V
Operating temperature	T <sub>opr</sub>	-30~+70	°C
Storage temperature	T <sub>stg</sub>	-40~+85	°C

Note: Voltage greater than above may damage the module

## 7. ELECTRICAL CHARACTERISTICS

### 7-1. DC Characteristics (V<sub>DD</sub>=1.8V ~ 5.5V, T<sub>a</sub>=-40~+85°C)

Symbol	Parameter	Min	Typ	Max	Unit	Test condition
V <sub>DD</sub>	Logic Circuit supply voltage	2.9	3.0	3.1	V	Recommend operating voltage
I <sub>DD</sub>	Current Consumption	-	0.2	0.5	mA	V <sub>LCD</sub> =V <sub>SS</sub>
V <sub>OH</sub>	High level output voltage	V <sub>DD</sub> -0.05	-	-	V	I <sub>OH</sub> =0 mA
V <sub>OL</sub>	Low level output voltage	-	-	0.05	V	I <sub>OH</sub> =0mA
V <sub>IH</sub>	High level input voltage	0.7V <sub>DD</sub>	-	V <sub>DD</sub>	V	
V <sub>IL</sub>	Low level input voltage	V <sub>SS</sub>	-	0.3V <sub>DD</sub>	V	
I <sub>OH</sub>	High level output current	-1	-	-	mA	V <sub>OH</sub> =4V, V <sub>DD</sub> =5V
I <sub>OL</sub>	Low level output current	3	-	-	mA	V <sub>OH</sub> =4V, V <sub>DD</sub> =5V
I <sub>ILI</sub>	Leakage current	-1		1	uA	V=V <sub>DD</sub> or V <sub>SS</sub>
C <sub>I</sub>	Input capacitance	-	-	7	pF	
V <sub>LCD</sub>	LCD driving voltage		3.0		V	V <sub>LCD</sub> - V <sub>SS</sub> , T <sub>a</sub> =25°C



**7-2.AC Characteristics** ( $V_{DD} = 1.8$  to  $5.5$  V;  $V_{SS} = 0$  V;  $T_{amb} = -40$  to  $+85$  °C)

SYMBOL	PARAMETER	CONDITIONS	MIN.	TYP.	MAX.	UNIT
f <sub>CLK</sub>	oscillator frequency	note 1	960	1890	2640	Hz
t <sub>CLKH</sub>	input CLK HIGH time		60	-	-	µs
t <sub>CLKL</sub>	input CLK LOW time		60	-	-	µs
t <sub>PD(SYNC)</sub>	SYNC propagation delay		-	30	-	ns
t <sub>SYNCL</sub>	SYNC LOW time		1	-	-	µs
t <sub>PD(LCD)</sub>	driver delays with test loads	V <sub>LCD</sub> = 5 V; note 2	-	-	30	µs
<b>Timing characteristics: I<sup>2</sup>C-bus; note 3</b>						
f <sub>SCL</sub>	SCL clock frequency		-	-	400	kHz
t <sub>BUF</sub>	bus free time between a STOP and START		1.3	-	-	µs
t <sub>HD;STA</sub>	START condition hold time		0.6	-	-	µs
t <sub>SU;STA</sub>	set-up time for a repeated START condition		0.6	-	-	µs
t <sub>LOW</sub>	SCL LOW time		1.3	-	-	µs
t <sub>HIGH</sub>	SCL HIGH time		0.6	-	-	µs
t <sub>r</sub>	SCL and SDA rise time	f <sub>SCL</sub> = 400 kHz	-	-	0.3	µs
		f <sub>SCL</sub> < 125 kHz	-	-	1.0	µs
t <sub>f</sub>	SCL and SDA fall time		-	-	0.3	µs
C <sub>B</sub>	capacitive bus line load		-	-	400	pF
t <sub>SU;DAT</sub>	data set-up time		100	-	-	ns
t <sub>HD;DAT</sub>	data hold time		0	-	-	ns
t <sub>SU;STO</sub>	set-up time for STOP condition		0.6	-	-	µs
t <sub>SW</sub>	tolerable spike width on bus		-	-	50	ns

**Notes**

- 1 Typical output duty factor: 50% measured at the CLK output pin.
- 2 Not tested in production.
- 3 All timing values are valid within the operating supply voltage and ambient temperature range and are referenced to V<sub>IL</sub> and V<sub>IH</sub> with an input voltage swing of V<sub>SS</sub> to V<sub>DD</sub>.

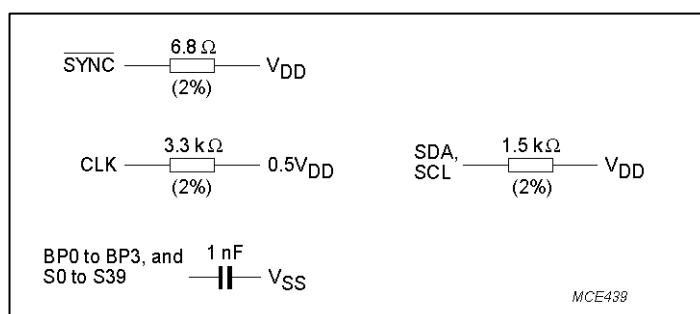



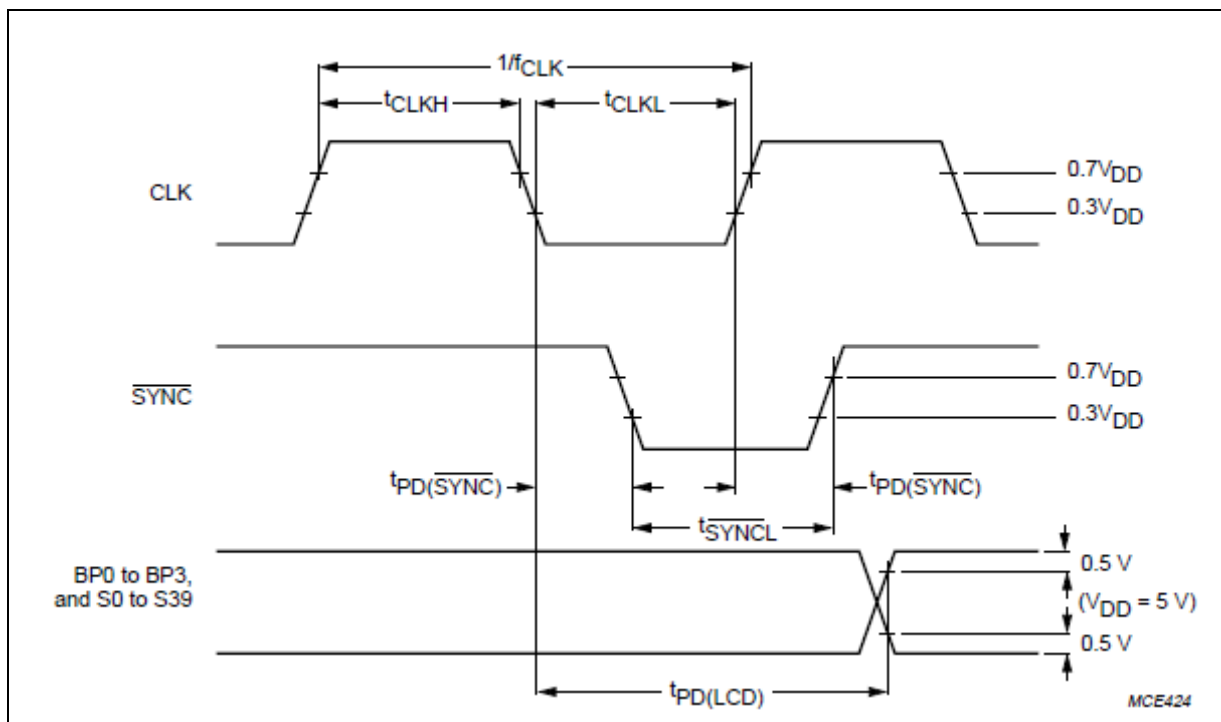

Fig. 1 Driver timing waveforms.

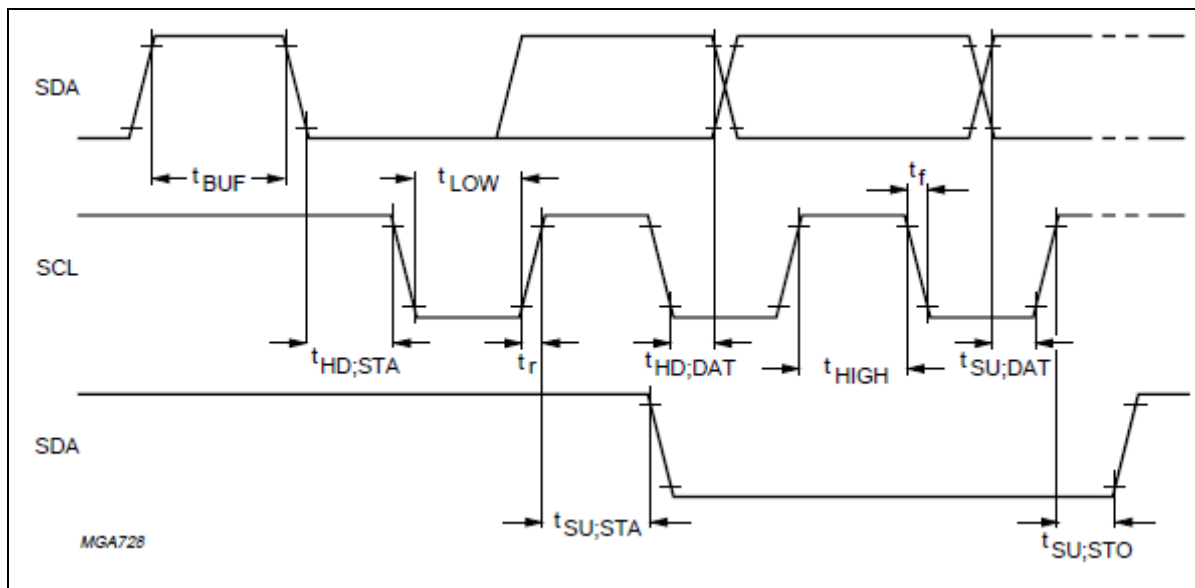
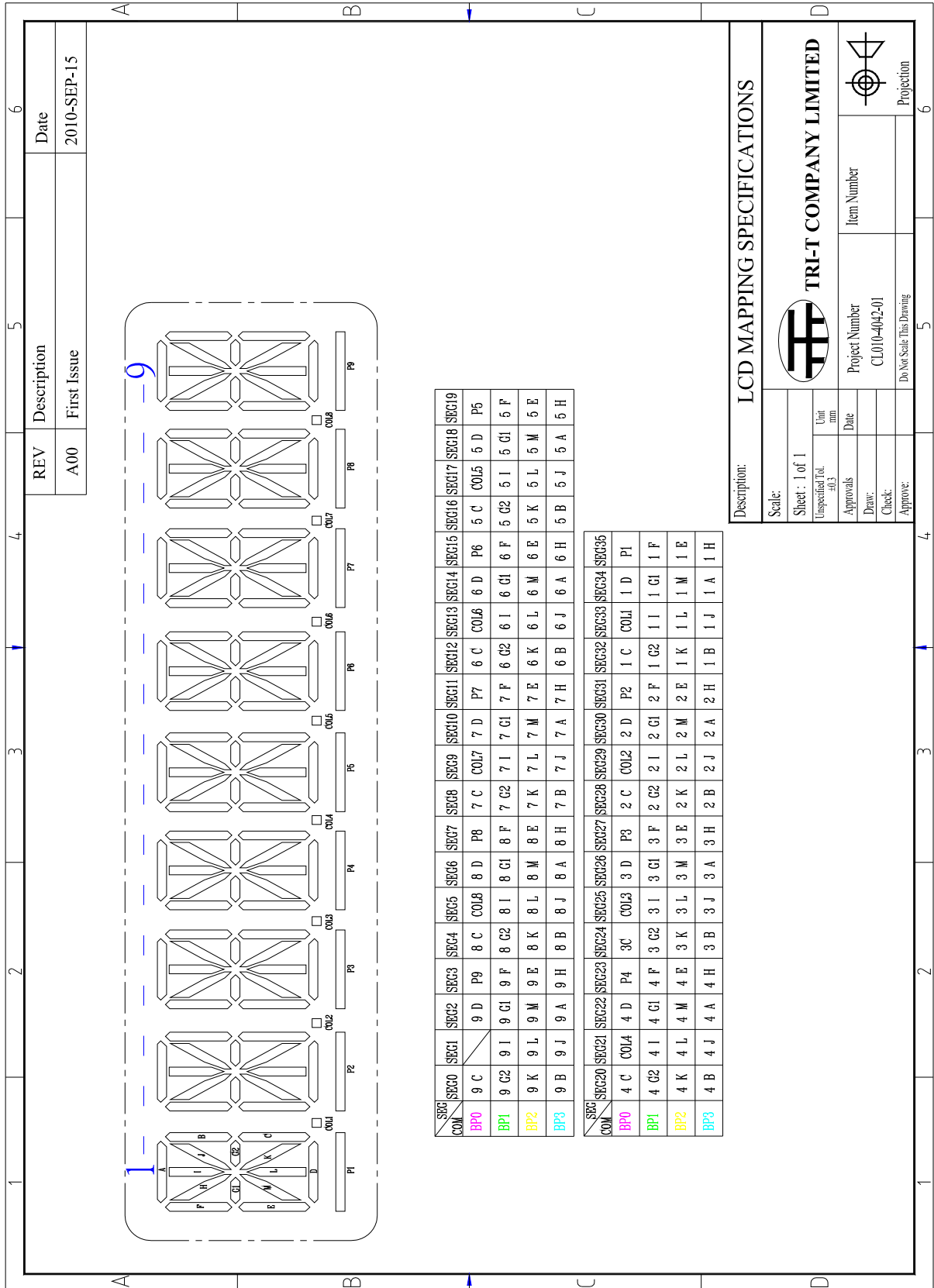

Fig. 2 I<sup>2</sup>C-bus timing waveforms.



**8.0 LCD MAPPING SPECIFICATIONS**



REV	Description	Date
A00	First Issue	2010-SEP-15

SEG	SEG1	SEG2	SEG3	SEG4	SEG5	SEG6	SEG7	SEG8	SEG9	SEG10	SEG11	SEG12	SEG13	SEG14	SEG15	SEG16	SEG17	SEG18	SEG19
COM	9 C	9 D	9 E	9 F	9 G	9 H	9 I	9 J	9 K	9 L	9 M	9 N	9 O	9 P	9 Q	9 R	9 S	9 T	9 U
BP0	9 C	9 D	9 E	9 F	9 G	9 H	9 I	9 J	9 K	9 L	9 M	9 N	9 O	9 P	9 Q	9 R	9 S	9 T	9 U
BP1	9 C	9 D	9 E	9 F	9 G	9 H	9 I	9 J	9 K	9 L	9 M	9 N	9 O	9 P	9 Q	9 R	9 S	9 T	9 U
BP2	9 C	9 D	9 E	9 F	9 G	9 H	9 I	9 J	9 K	9 L	9 M	9 N	9 O	9 P	9 Q	9 R	9 S	9 T	9 U
BP3	9 C	9 D	9 E	9 F	9 G	9 H	9 I	9 J	9 K	9 L	9 M	9 N	9 O	9 P	9 Q	9 R	9 S	9 T	9 U

SEG	SEG20	SEG21	SEG22	SEG23	SEG24	SEG25	SEG26	SEG27	SEG28	SEG29	SEG30	SEG31	SEG32	SEG33	SEG34	SEG35
COM	4 C	4 D	4 E	4 F	4 G	4 H	4 I	4 J	4 K	4 L	4 M	4 N	4 O	4 P	4 Q	4 R
BP0	4 C	4 D	4 E	4 F	4 G	4 H	4 I	4 J	4 K	4 L	4 M	4 N	4 O	4 P	4 Q	4 R
BP1	4 C	4 D	4 E	4 F	4 G	4 H	4 I	4 J	4 K	4 L	4 M	4 N	4 O	4 P	4 Q	4 R
BP2	4 C	4 D	4 E	4 F	4 G	4 H	4 I	4 J	4 K	4 L	4 M	4 N	4 O	4 P	4 Q	4 R
BP3	4 C	4 D	4 E	4 F	4 G	4 H	4 I	4 J	4 K	4 L	4 M	4 N	4 O	4 P	4 Q	4 R

**LCD MAPPING SPECIFICATIONS**

Description:

Scale: Sheet : 1 of 1  
Unspecified Tol. ±0.3  
Unit mm

Project Number: CL010-042-01  
Item Number:   
Date:   
Draw:   
Check:   
Approve:   
Do Not Scale This Drawing

**TRI-T COMPANY LIMITED**

Projection:



## **9. QUALITY SPECIFICATIONS**

### **9.1 Inspection Condition**

9.1.1 The inspection shall be performed by using 20W x 2 fluorescent lamps . Distance between LCD and fluorescent lamps should be 100 cm or more. Distance between LCD and inspector eyes should be 30 cm or more.

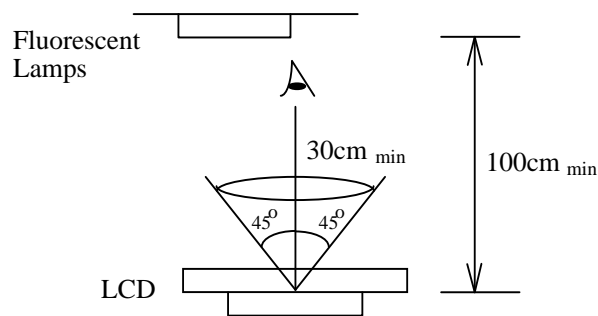

9.1.2 For transmissive displays a reflector (e.g. a white card) shall be placed behind the display.

9.1.3 Viewing direction for inspection is  $45^\circ$  from vertical against LCD.

### **9.2. Definition of Zone**

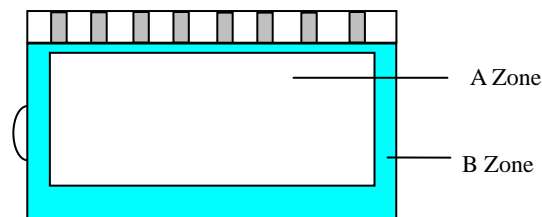

A Zone: Active display area (minimum viewing area).

B Zone: Non-active display area (outside viewing area).



**9.3 Sampling Method: MIL-STD-105E.**

**9.4 Inspection level: Level II, Single Sampling.**

Rank	Item		Criterion	AQL
Major	1. Display state	1. Segment short circuit.	1	0.4
		2. Open circuit (missing segment)		
		3. Contrast defect (dim, ghosting)		
		4. Segment defect (Pin hole, etc.)	6	
		5. Leakage	/	Ac:0 Re: 1
	6. No display, polarizers reverse applied			
	2. Dimension	1. Dimension out of specification (incl. PIN)	2	0.4
Minor	1. Non-display state	1. Spot, foreign material, line defect	3, 4, 5	1.0
		2. Rainbow, background color		
	2. Polarizer	1. Scratch	3, 4, 7	
		2. Bubble		
		3. Foreign material		
		4. Poor fixed position	8	
	3. Glass substrate	1. Chipped	9	
		2. Protruded, burred	10	
	4. PIN	1. Positioning	11	
		2. Epoxy coverage		
5. Silk screen	1. Positioning	12		
	2. Color			
	3. Semblance defect (Refer spot, line Standards)	3, 4		
Total				1.0

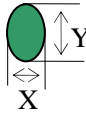
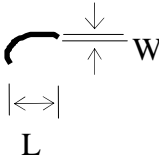
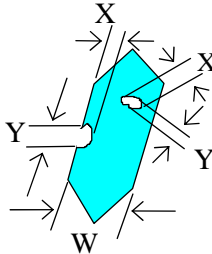

9.5 Inspection Items and Standards

No	Item	Criterion																				
1	Segment short, missing	Not exist																				
	Contrast defect	Refer to approved sample																				
2	Outside defect、 Positioning Color	Not exceed tolerance Refer to approved sample																				
3	Point defect, Black spot, dust (incl. Polarizer)  $\phi = (X+Y)/2$	 <table border="1" data-bbox="940 645 1378 949"> <thead> <tr> <th>Point Size</th> <th>Acceptable Qty.</th> </tr> </thead> <tbody> <tr> <td><math>\phi \leq 0.10</math></td> <td>Not count</td> </tr> <tr> <td><math>0.10 &lt; \phi \leq 0.20</math></td> <td>1</td> </tr> <tr> <td><math>0.20 &lt; \phi \leq 0.25</math></td> <td>2</td> </tr> <tr> <td><math>0.25 &lt; \phi \leq 0.30</math></td> <td>1</td> </tr> <tr> <td><math>\phi &gt; 0.30</math></td> <td>0</td> </tr> </tbody> </table> <p style="text-align: center;">Unit : mm</p>	Point Size	Acceptable Qty.	$\phi \leq 0.10$	Not count	$0.10 < \phi \leq 0.20$	1	$0.20 < \phi \leq 0.25$	2	$0.25 < \phi \leq 0.30$	1	$\phi > 0.30$	0								
Point Size	Acceptable Qty.																					
$\phi \leq 0.10$	Not count																					
$0.10 < \phi \leq 0.20$	1																					
$0.20 < \phi \leq 0.25$	2																					
$0.25 < \phi \leq 0.30$	1																					
$\phi > 0.30$	0																					
4	Line defect	 <table border="1" data-bbox="879 1113 1431 1382"> <thead> <tr> <th colspan="2">Line</th> <th>Acceptable Qty.</th> </tr> <tr> <th>L</th> <th>W</th> <th></th> </tr> </thead> <tbody> <tr> <td>---</td> <td><math>0.015 \geq W</math></td> <td>Disregard</td> </tr> <tr> <td><math>3.0 \geq L</math></td> <td><math>0.03 \geq W</math></td> <td rowspan="2">1</td> </tr> <tr> <td><math>2.0 \geq L</math></td> <td><math>0.05 \geq W</math></td> </tr> <tr> <td><math>1.0 \geq L</math></td> <td><math>0.1 &gt; W</math></td> <td>0</td> </tr> <tr> <td>---</td> <td><math>0.05 &lt; W</math></td> <td>Applied as point defect</td> </tr> </tbody> </table> <p style="text-align: center;">Unit: mm</p>	Line		Acceptable Qty.	L	W		---	$0.015 \geq W$	Disregard	$3.0 \geq L$	$0.03 \geq W$	1	$2.0 \geq L$	$0.05 \geq W$	$1.0 \geq L$	$0.1 > W$	0	---	$0.05 < W$	Applied as point defect
Line		Acceptable Qty.																				
L	W																					
---	$0.015 \geq W$	Disregard																				
$3.0 \geq L$	$0.03 \geq W$	1																				
$2.0 \geq L$	$0.05 \geq W$																					
$1.0 \geq L$	$0.1 > W$	0																				
---	$0.05 < W$	Applied as point defect																				
5	Rainbow	Not more than two color changes across the viewing area. Background color should refer to approved sample .																				
6	Segment pattern  W = Segment width  $\phi = (A+B)/2$	<p>1. Pin hole <math>\phi &lt; 0.10\text{mm}</math> is acceptable.</p>  <table border="1" data-bbox="962 1695 1422 1832"> <thead> <tr> <th>Width</th> <th>Acceptable of defect</th> </tr> </thead> <tbody> <tr> <td><math>W &lt; 0.4</math></td> <td><math>\phi \leq 1/2W</math> and, <math>\phi \leq 0.2</math></td> </tr> <tr> <td><math>W \geq 0.4</math></td> <td><math>\phi \leq 1/3W</math> and, <math>\phi \leq 0.25</math></td> </tr> </tbody> </table> <p style="text-align: center;">Unit: mm</p>	Width	Acceptable of defect	$W < 0.4$	$\phi \leq 1/2W$ and, $\phi \leq 0.2$	$W \geq 0.4$	$\phi \leq 1/3W$ and, $\phi \leq 0.25$														
Width	Acceptable of defect																					
$W < 0.4$	$\phi \leq 1/2W$ and, $\phi \leq 0.2$																					
$W \geq 0.4$	$\phi \leq 1/3W$ and, $\phi \leq 0.25$																					

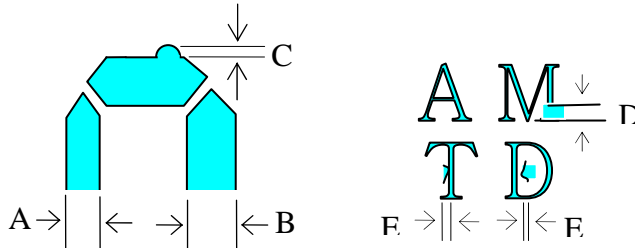
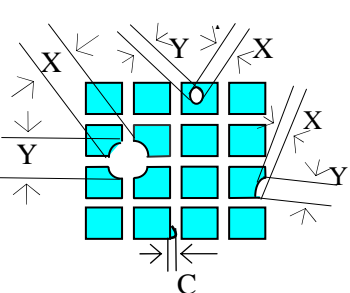

No	Item	Criterion												
		<p>2. Segment width acceptable.</p> <p><math> A - B  &lt; 0.20</math> ;      <math>D \leq 0.2</math>  <math>C \leq 0.1</math>                      <math>E \leq 0.15</math></p>  <p>3. Dot pattern</p>  <table border="1" data-bbox="1053 1008 1468 1209"> <thead> <tr> <th>Size</th> <th>Acceptable Qty.</th> </tr> </thead> <tbody> <tr> <td><math>\phi &lt; 0.1</math></td> <td>Disregard</td> </tr> <tr> <td><math>0.10 \leq \phi \leq 0.20</math></td> <td>1</td> </tr> <tr> <td><math>\phi &gt; 0.20</math></td> <td>0</td> </tr> </tbody> </table> <p>C: Shall not touch other dot(s).</p> <p style="text-align: right;">Unit: mm</p>	Size	Acceptable Qty.	$\phi < 0.1$	Disregard	$0.10 \leq \phi \leq 0.20$	1	$\phi > 0.20$	0				
Size	Acceptable Qty.													
$\phi < 0.1$	Disregard													
$0.10 \leq \phi \leq 0.20$	1													
$\phi > 0.20$	0													
7	Polarizer air bubble	<table border="1" data-bbox="734 1388 1244 1691"> <thead> <tr> <th>Size</th> <th>Acceptable Qty.</th> </tr> </thead> <tbody> <tr> <td><math>\phi &lt; 0.10</math> or B Zone</td> <td>Disregard</td> </tr> <tr> <td><math>0.10 &lt; \phi \leq 0.20</math></td> <td>2</td> </tr> <tr> <td><math>0.20 &lt; \phi \leq 0.50</math></td> <td>1</td> </tr> <tr> <td><math>0.50 &lt; \phi</math></td> <td>0</td> </tr> <tr> <td>Total</td> <td>2</td> </tr> </tbody> </table> <p style="text-align: right;">Unit: mm</p>	Size	Acceptable Qty.	$\phi < 0.10$ or B Zone	Disregard	$0.10 < \phi \leq 0.20$	2	$0.20 < \phi \leq 0.50$	1	$0.50 < \phi$	0	Total	2
Size	Acceptable Qty.													
$\phi < 0.10$ or B Zone	Disregard													
$0.10 < \phi \leq 0.20$	2													
$0.20 < \phi \leq 0.50$	1													
$0.50 < \phi$	0													
Total	2													
8	Polarizer mis-placement	Polarizer should neither extends to glass edge nor extends into seal.												

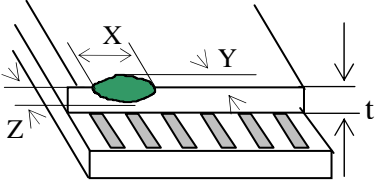
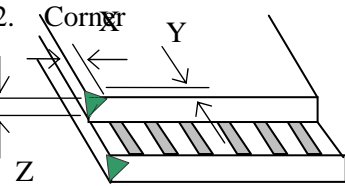
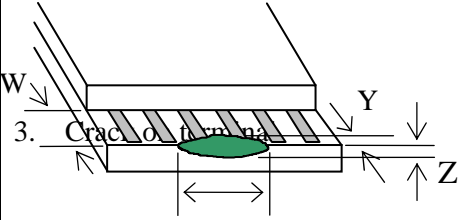
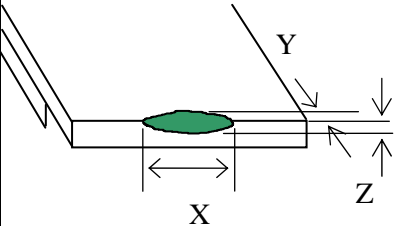

No	Item	Criterion																								
9	<p>Crack and chip</p> <p>Remark:</p> <p>X: Length direction</p> <p>Y: Short direction</p> <p>Z: Thickness direction</p> <p>t: Glass thickness</p> <p>a: LCD length</p> <p>W: Terminal Width</p> <p>F : seal width</p>	<p>1. General</p>  <table border="1" data-bbox="1054 517 1461 707"> <caption>Acceptable criterion</caption> <thead> <tr> <th>X</th> <th>Y</th> <th>Z</th> </tr> </thead> <tbody> <tr> <td>≤5mm</td> <td>shall not reach to 1F/3</td> <td>≤t/2</td> </tr> </tbody> </table> <p>2. Corner</p>  <table border="1" data-bbox="1054 896 1461 1086"> <caption>Acceptable criterion</caption> <thead> <tr> <th>X</th> <th>Y</th> <th>Z</th> </tr> </thead> <tbody> <tr> <td>≤5mm</td> <td>shall not reach to F/3</td> <td>≤t</td> </tr> </tbody> </table> <p>3. Crack on terminal</p>  <table border="1" data-bbox="1106 1355 1445 1500"> <caption>Acceptable criterion</caption> <thead> <tr> <th>X</th> <th>Y</th> <th>Z</th> </tr> </thead> <tbody> <tr> <td>≤a/10</td> <td>≤0.4</td> <td>≤t</td> </tr> </tbody> </table> <p>4. Other than terminal</p>  <table border="1" data-bbox="1054 1758 1461 1926"> <caption>Acceptable criterion</caption> <thead> <tr> <th>X</th> <th>Y</th> <th>Z</th> </tr> </thead> <tbody> <tr> <td>≤a/10</td> <td>shall not reach to F/3</td> <td>≤t/3</td> </tr> </tbody> </table>	X	Y	Z	≤5mm	shall not reach to 1F/3	≤t/2	X	Y	Z	≤5mm	shall not reach to F/3	≤t	X	Y	Z	≤a/10	≤0.4	≤t	X	Y	Z	≤a/10	shall not reach to F/3	≤t/3
X	Y	Z																								
≤5mm	shall not reach to 1F/3	≤t/2																								
X	Y	Z																								
≤5mm	shall not reach to F/3	≤t																								
X	Y	Z																								
≤a/10	≤0.4	≤t																								
X	Y	Z																								
≤a/10	shall not reach to F/3	≤t/3																								

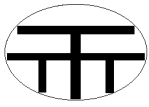

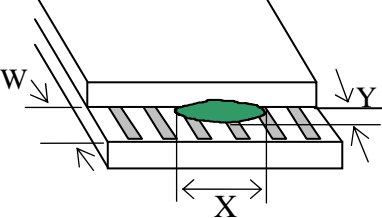
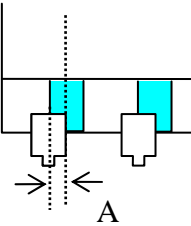
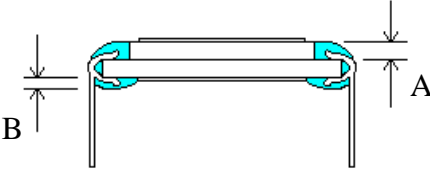
No	Item	Criterion
10	Protruded W: Terminal Width	 <p>Acceptable criteria:  <math>Y \leq 1/5W</math></p>
11	Pin	<p>1. Positioning</p>  <p>2. Epoxy coverage</p>  <p>A · B Epoxy Maximum height shall extend above front rear polarizer surface</p> <p>3. No stain, rust nor discoloration of the insulating portion shall be allowed.</p>
12	Total no. of acceptable defect	<p>A. Zone</p> <p>Maximum 4 non-conformities per one unit.          Defect distance: each point to be separated over 5mm</p> <p>B. Zone</p> <p>It is acceptable when it is no trouble for quality and assembly in customer's end product.</p>





**9.6 Reliability Standards**

Reliability test condition:

Item	Condition	Time (hrs)	Assessment
High temp. Storage	80°C	240	No abnormalities in functions and appearance
High temp. Operating	70°C	240	
Low temp. Storage	-40°C	240	
Low temp. Operating	-20°C	240	
Humidity	40°C/ 90%RH	240	
Temp. Cycle	-40°C ← 25°C →80°C (30 min ← 5 min → 30min)	10cycles	

Recovery time should be 24 hours minimum. Moreover, functions, performance and appearance shall be free from remarkable deterioration within 50,000 hours under ordinary operating and storage conditions room temperature (20±8°C), normal humidity (below 65% RH), and in the area not exposed to direct sun light.

**9-7. Precaution for using COG**

COG is assembled and adjusted with a high degree of precision. Do not attempt to make any alteration or modification. The followings should be noted.

**General Precautions:**

1. LCD panel is made of glass. Avoid excessive mechanical shock or applying strong pressure onto the surface of display area.
2. The polarizer used on the display surface is easily scratched and damaged. Extreme care should be taken when handling. To clean dust or dirt off the display surface, wipe gently with cotton, or other soft material soaked with isopropyl alcohol, ethyl alcohol or trichlorotrifluoroethane, do not use water, ketone or aromatics and never scrub hard.
3. Do not tamper in any way with the tabs on the metal frame.
4. Do not made any modification on the PCB without consulting TRI-T.
5. Be careful not to touch or swallow liquid crystal that might leak from a damaged cell. Any liquid crystal adheres to skin or clothes, wash it off immediately with soap and water.

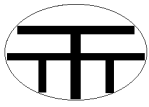

**Static Electricity Precautions:**

1. CMOS-LSI is used for the module circuit; therefore operators should be grounded whenever he/she comes into contact with the module.
2. Do not touch any of the conductive parts such as the LSI pads; the copper leads on the PCB and the interface terminals with any parts of the human body.
3. Do not touch the connection terminals of the display with bare hand; it will cause disconnection or defective insulation of terminals.
4. The modules should be kept in anti-static bags or other containers resistant to static for storage.
5. Only properly grounded soldering irons should be used.
6. If an electric screwdriver is used, it should be grounded and shielded to prevent sparks.
7. The normal static prevention measures should be observed for work clothes and working benches.
8. Since dry air is inductive to static, a relative humidity of 50-60% is recommended.

**Soldering Precautions:**

1. Soldering should be performed only on the I/O terminals.
2. Use soldering irons with proper grounding and no leakage.
3. Soldering temperature:  $280^{\circ}\text{C} \pm 10^{\circ}\text{C}$
4. Soldering time: 3 to 4 second.
5. Use eutectic solder with resin flux filling.
6. If flux is used, the LCD surface should be protected to avoid spattering flux.
7. Flux residue should be removed.

**Operation Precautions:**

1. The viewing angle can be adjusted by varying the LCD driving voltage  $V_o$ .
2. Since applied DC voltage causes electro-chemical reactions, which deteriorate the display, the applied pulse waveform should be a symmetric waveform such that no DC component remains. Be sure to use the specified operating voltage.
3. Driving voltage should be kept within specified range; excess voltage will shorten display life.
4. Response time increases with decrease in temperature.
5. Display color may be affected at temperatures above its operational range.



## ***TRI-T COMPANY LIMITED***

---

### **Operation Precautions:**

1. Keep the temperature within the specified range usage and storage. Excessive temperature and humidity could cause polarization degradation, polarizer peel-off or generate bubbles.
2. For long-term storage over 40°C is required, the relative humidity should be kept below 60%. Avoid direct sunlight.

### **Limited Warranty**

TRI-T modules are not consumer products, but may be incorporated by TRI-T's customers into consumer products or components thereof, TRI-T does not warrant that its modules and components are fit for any such particular purpose.

1. The liability of TRI-T is limited to repair or replacement on the terms set forth below. TRI-T will not be responsible for any subsequent or consequential events or injury or damage to any personnel or user including third party personnel and/or user. Unless otherwise agreed in writing between TRI-T and the customer, TRI-T will only replace or repair any of its LCD which is found defective electrically or visually when inspected in accordance with TRI-T QUALITY INSPECTION STANDARD.
2. No warranty can be granted if any of the precautions state in handling liquid crystal display above has been disregarded. Broken glass, scratches on polarizer mechanical damages as well as defects that are caused accelerated environment tests are excluded from warranty.
3. In returning the LCM, they must be properly packaged; there should be detailed description of the failures or defect.