

PIC-P14 development board

Users Manual

Rev.B, June 2007

Copyright(c) 2007, OLIMEX Ltd, All rights reserved

INTRODUCTION:

PIC-P14 board is development board which allow you to prototype and develop code for all Microchip's PIC microcontrollers with 14 pins.

What you can do with PIC-P14? A lot of stuff let's see what we have:

PIC-P14 have RS232 connector and driver, so you can interface your PIC microcontroller to other embedded or PC with RS232. The RS232 driver have 4 lines Tx, Rx, CTS and jumper selectable RTS or DTR. The pin labeled RX is output and should be connected to PIC UART Tx. The pin labeled TX is input and should be connected to PIC UART Rx. Note that MAX232 driver on the socket is 5V device, so if you decide to run your PIC on 3.3V you should replace it with MAX3232 which works on 3.3V

The on-board ICSP connector allow you to program the PIC on the board without pulling it of the socket, by ICSP programmer like PIC-MCP, PIC-MCP-USB, PIC-PG1, PIC-PG2, PIC-PG3, PIC-PG4 or to program and debug it with PIC-ICD2, PIC-ICD2-POCKET or PIC-ICD2-TINY. **IMPORTANT: all programmers provide power supply through ICSP connector during the programming PIC-P18 should not be powered via the external power jack!**

The power supply circuit have diode bridge after the power supply jack which allow you to power this board with both AC and DC power supply adapters. The input voltage could be anything within the range +7.5 - 15V DC or 6-12V AC.

Voltage regulator is made with LM317 adjustable voltage regulator and have jumper which selects what voltage you supply to the PIC microcontroller +3.3V or +5V, so you can work with PICs on both low and normal voltage.

The oscillator circuit is made with 20 Mhz crystal oscillator, so you can run your PIC at maximum performance.

The RESET circuit is made with simple RC circuit and RESET push button, the reason to not use RESET IC is that the board should support both 3.3V and 5V operation while RESET ICs are on fixed voltage.

PIC-P14 have user button for user input connected to PIC microcontroller's RC3 port. When RC3 port is initialized as INPUT you will read "0" when the button is pressed and "1" when it is depressed.

Status LED is connected via jumper to PIC microcontroller's RC2 port. When your RC2 port is initialized as OUTPUT and set to "0" LED will go ON, when RC2 port is set to "1" LED will go OFF.

PIC-P14 have handy GND pin for connection to oscilloscope.

FEATURES:

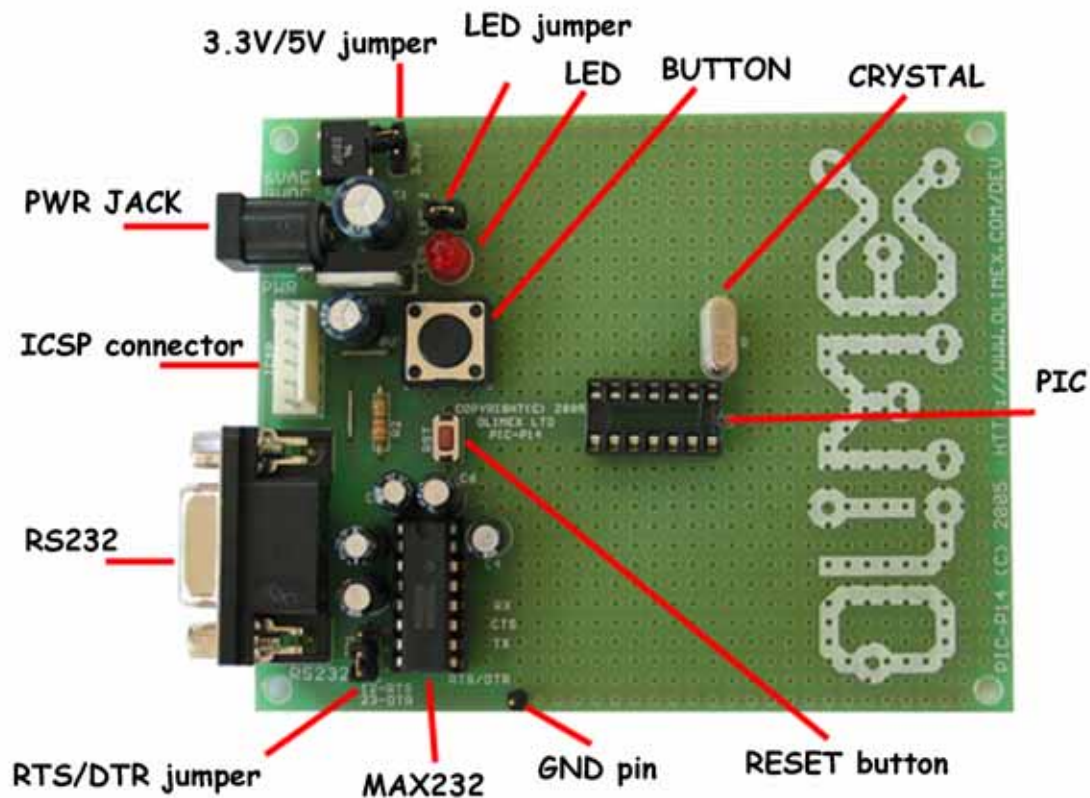

- ICSP/ICD connector for programming and debugging
- RS232 interface with MAX232 IC on socket
- DIL14 microcontroller socket
- Quartz crystal 20Mhz
- LED to RC2 through jumper
- user Button to RC3
- Reset button and circuit
- Power plug-in jack, accept AC and DC input
- selectable +3.3V / +5V power supply voltage regulator (3.3V when jumper is closed)
- Extension slot on every uC pin
- Gird 100 mils
- GND bus
- Vcc bus
- Four mounting holes 3,3 mm (0,13")
- FR-4, 1.5 mm (0,062"), green soldermask, white silkscreen component print
- Dimensions 100x80 mm (3,9x3,15")



All boards produced by Olimex are ROHS compliant

HARDWARE:

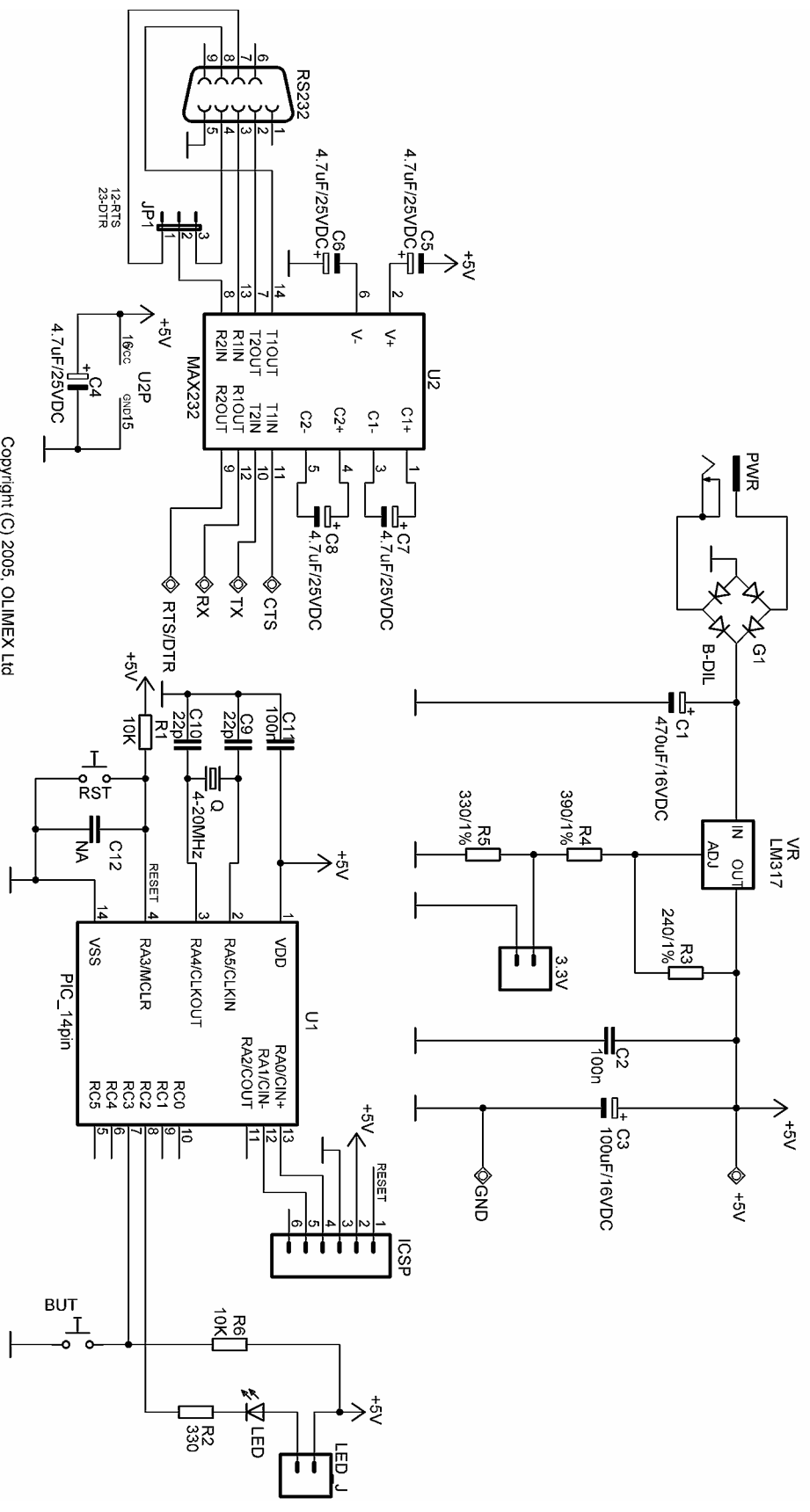

Copyright (C) 2005, OLIMEX Ltd
<http://www.olimex.com/dev>

SOFTWARE:

DEMO1: PIC16F688-I/P BLINK LED

This is demo code which blinks the LED on PIC-P14 board.

Note:

LED jumper should be closed!

```
//PROGRAMM FOR BLINKING LED
//
// PROCESSOR : PIC16F688
// CLOCK      : 20MHz, EXTERNAL

#include      <pic.h>

__CONFIG(WDTDIS & MCLREN & BORDIS & HS & PWRTEN & FCMDIS & IESODIS) ;

//Just simple delay
void Delay(unsigned long cntr) {
    while (--cntr != 0);
}

// main function
void main( void ) {

    OPTION          = 0x80;          // GPIO pull-ups are disabled
    INTCON           = 0x0;          // Disable inerrupt
    WPUA = 0x0;       // pull-up disable
    ANSEL            = 0x0;          // port as Digital IO
    CMCON0           = 0x07;        // port as Digital IO
    TRISC2           = 0;           // Led pin as output

    // loop forever - echo
    while(1) {

        // Toggle led
        PORTC ^= 0x04;
        // Simple delay
        Delay(50000);
    }
}
```

DEMO2: PIC16F688-I/P BUTTON read

This is demo code which show how to read BUTTON status

DEMO3: PIC16F688-I/P RS232 send / receive routines

This is demo code which show how to use the USART to send and receive characters from host PC via RS232 cable.

The MAX232 by default is not connected to PIC on the board so you have to solder two wires – one from RC4 (pin #6) of PIC16F688 Tx signal to MAX232 Tx labeled pin, and second from RC5 (pin #5) of PIC16F688 Rx signal to MAX232 Rx labeled pin.

You must program the HEX code to PIC16F688 and run the code.

If you programmed the PIC correctly and wired the UART, when you open Hyperterminal on your host PC computer with 9600 bps, 8 data bit, 1 stop bit, No flow control and apply power supply to the PIC-P14 every character

you type on the hyperterminal will be printed back with "*" i.e. if you type "abc" you will receive "a*b*c*".

```
//PROGRAMM FOR rs232 communication
//
// PROCESSOR : PIC16F688
// CLOCK     : 20MHz, EXTERNAL
// SPEED     : 9600 bps(1bit=104us)

#include      <pic.h>

__CONFIG(WDTDIS & MCLREN & BORDIS & HS & PWRTEN & FCMDIS & IESODIS) ;

unsigned char ch;

void InitUsart(void) {

    // TX Pin - output
    TRISC4 = 0;

    // RX Pin - input
    TRISC5 = 1;

    // RX Setting, 8bit, enable receive,
    RCSTA = 0x90;

    // TX Setting, 8bit, Asynchronous mode, High speed
    TXSTA = 0x24;

    // Baudcontrol - disable auto mode, 8bit baudrate
    BAUDCTL = 0x00;

    // Set Baudrate - 9600 (from datasheet baudrate table)
    SPBRG = 129;

}

void WriteByte(unsigned char byte) {

    // wait until register is empty
    while(!TXIF);

    // transmute byte
    TXREG = byte;

}

unsigned char ReadByte(void) {

    // wait to receive character
    while(!RCIF);

    // return received character
    return RCREG;

}

// main function
void main( void ) {

    // Init Interface
    InitUsart();

    // loop forever - echo
    while(1) {
        ch = ReadByte();    //wait to receive character
        WriteByte(ch);     //send it back followed by "*"
        WriteByte('*');
    }

}
```

ORDER CODE:

PIC-P14 – assembled and tested (no kit, no soldering required)

PIC-P14/PCB – blank PCBs only

How to order?

You can order to us directly or by any of our distributors.

Check our web www.olimex.com/dev for more info.

Revision history:

REV.A - create

REV.B - add software demo codes

Disclaimer:

© 2007 Olimex Ltd. All rights reserved. Olimex®, logo and combinations thereof, are registered trademarks of Olimex Ltd. Other terms and product names may be trademarks of others.

The information in this document is provided in connection with Olimex products. No license, express or implied or otherwise, to any intellectual property right is granted by this document or in connection with the sale of Olimex products.

Neither the whole nor any part of the information contained in or the product described in this document may be adapted or reproduced in any material from except with the prior written permission of the copyright holder.

The product described in this document is subject to continuous development and improvements. All particulars of the product and its use contained in this document are given by OLIMEX in good faith. However all warranties implied or expressed including but not limited to implied warranties of merchantability or fitness for purpose are excluded.

This document is intended only to assist the reader in the use of the product. OLIMEX Ltd. shall not be liable for any loss or damage arising from the use of any information in this document or any error or omission in such information or any incorrect use of the product.