

LPC-H3131 development board

Users Manual



All boards produced by Olimex are ROHS compliant

Rev. Initial, May 2010

Copyright(c) 2010, OLIMEX Ltd, All rights reserved

INTRODUCTION

LPC-H3131 board includes powerful LPC3131 180 MHz ARM microcontroller, with 4 Gb NAND FLASH, 256 Mb SDRAM, which gives user opportunity to run Embedded Linux operation systems. In addition there is audio codec, which gives chance to be made audio signal processing; USB_OTG; USB to UART; mini SD/MMC card connector. There are plenty of GPIOs on extension headers where you can connect your additional circuits.

BOARD FEATURES

- MCU: **LPC3131** ARM9 32-bit ARM926EJ-S, 180Mhz, 192 kB RAM, NAND flash controller with 8-bit ECC, High-speed USB 2.0 (OTG, Host, Device) with on-chip PHY, Two I2S-bus interfaces Integrated master/slave SPI Two master/slave I2C-bus interfaces Fast UART Memory Card Interface (MCI): MMC/SD/SDIO/CE-ATA Four-channel 10-bit ADC
- 4G-Bit NAND Flash Memory: 512M x 8Bit (2.7-3.6)V - K9F4G08U0M
- 256Mbit SDRAM: 4Meg x 16Bit x 4Banks (3.00-3.6)V - K4S561632C-TC
- SPI-FLASH - AT45DB161D-SU
- Reset circuit
- Reset button
- Clock circuit
- Four on-board voltage regulators:
 - VR1 (5V)
 - VR2 (3.3V)
 - VR3 (VDD = 3.083V)
 - VR4 (1.25V)
- Two user leds
- JTAG connector
- mini SD/MMC connector
- USB to UART converter
- USB_OTG connector
- Power Jack
- Power LED
- Audio codec - UDA1380TT/N2, which provide:
 - Audio In and Audio Out
 - Audio Amplifier Stereo Out connected to jack
- FR-4, 1.5 mm (0,062"), soldermask, silkscreen component print
- dimensions 90x60 mm (3.54x2.36")

ELECTROSTATIC WARNING

The LPC-H3131 board is shipped in protective anti-static packaging. The board must not be subject to high electrostatic potentials. General practice for working with static sensitive devices should be applied when working with this board.

BOARD USE REQUIREMENTS

Cables: The cable you will need depends on the programmer/debugger you use. If you use ARM-USB-TINY or ARM-USB-TINY-H, you will need USB A-B cable and if you use ARM-USB-OCD, you will need RS232 and USB A-B cable.

Hardware: One of OLIMEX Programmers/Debuggers - [ARM-USB-OCD](#), [ARM-USB-TINY](#) or [ARM-USB-TINY-H](#), but we do not offer projects with this programmers.

PROCESSOR FEATURES

LPC-H3131 board use Low-cost, low-power ARM926EJ-S microcontroller with high-speed USB 2.0 OTG, SD/MMC and NAND Flash controller, with these features:

- CPU platform
 - 180 MHz, 32-bit ARM926EJ-S
 - 16 kB D-cache and 16 kB I-cache
 - Memory Management Unit (MMU)
- Internal memory
 - 192 kB embedded SRAM
- External memory interface
 - NAND flash controller with 8-bit ECC
 - 8/16-bit Multi-Port Memory Controller (MPMC): SDRAM and SRAM
- Communication and connectivity
 - High-speed USB 2.0 (OTG, Host, Device) with on-chip PHY
 - Two I²S-bus interfaces
 - Integrated master/slave SPI
 - Two master/slave I²C-bus interfaces
 - Fast UART
 - Memory Card Interface (MCI): MMC/SD/SDIO/CE-ATA
 - Four-channel 10-bit ADC
 - Integrated 4/8/16-bit 6800/8080 compatible LCD interface
- System functions

- Dynamic clock gating and scaling
- Multiple power domains
- Selectable boot-up: SPI flash, NAND flash, SD/MMC cards, UART, or USB
- DMA controller
- Four 32-bit timers
- Watchdog timer
- PWM module
- Random Number Generator (RNG)
- General Purpose I/O (GPIO) pins
- Flexible and versatile interrupt structure
- JTAG interface with boundary scan and ARM debug access
- Operating voltage and temperature
 - Core voltage: 1.2 V
 - I/O voltage: 1.8 V, 2.8 V, 3.3 V

BLOCK DIAGRAM

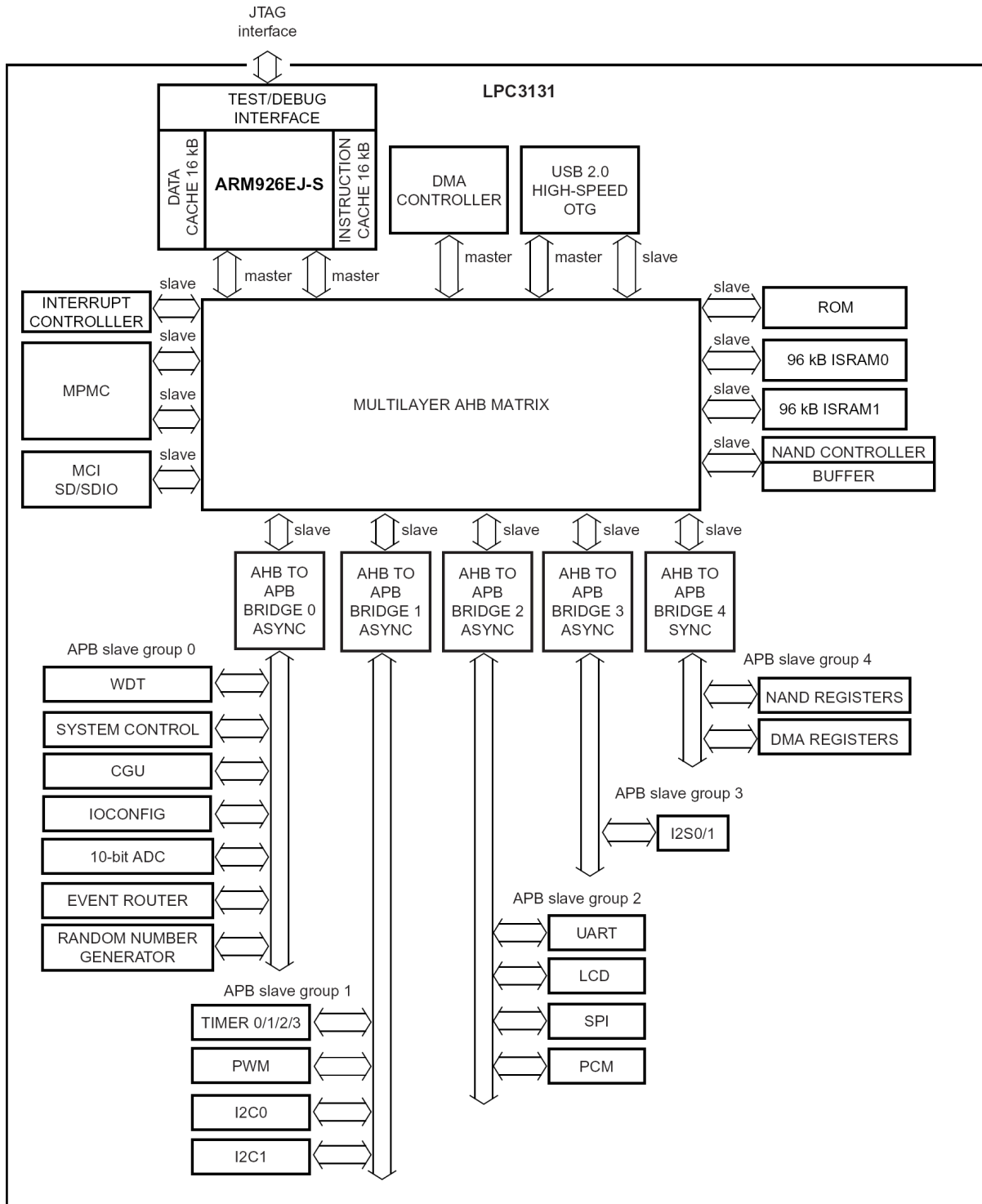

MEMORY MAP

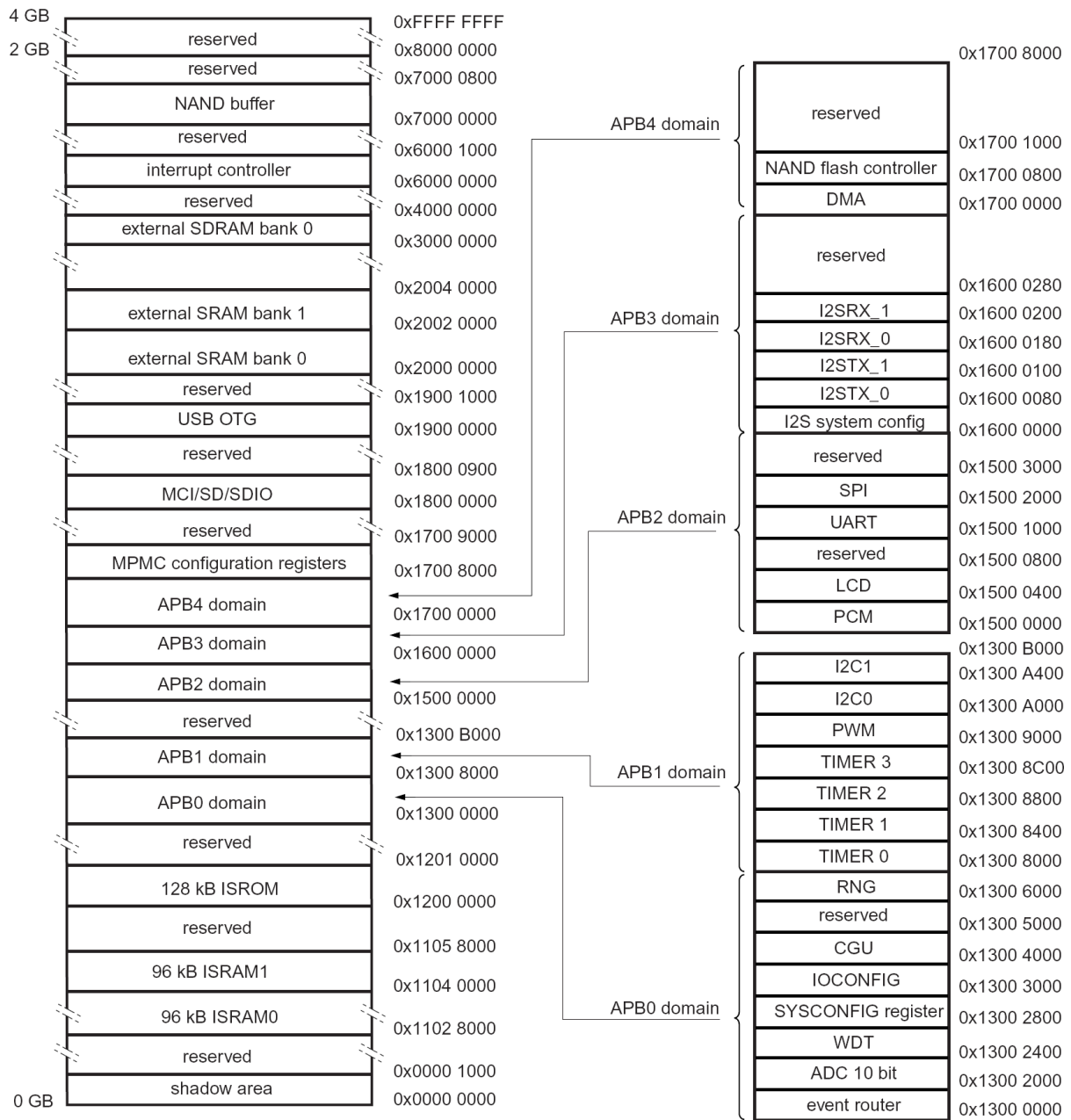

SCHEMATIC

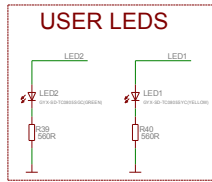
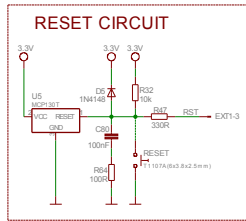

LPC-H3131

Rev: Initial
 COPYRIGHT(C) 2010, OLIMEX LTD.
 http://www.olimex.com/dev

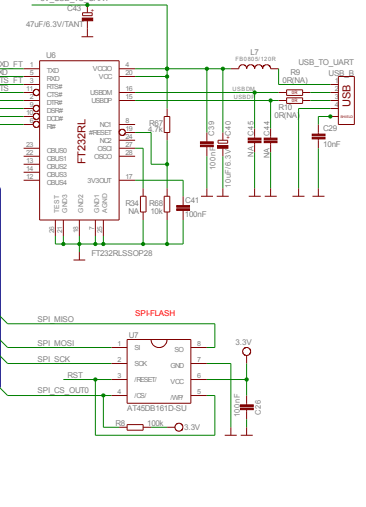
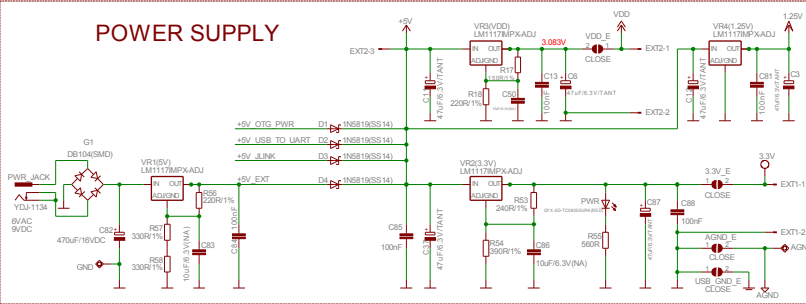
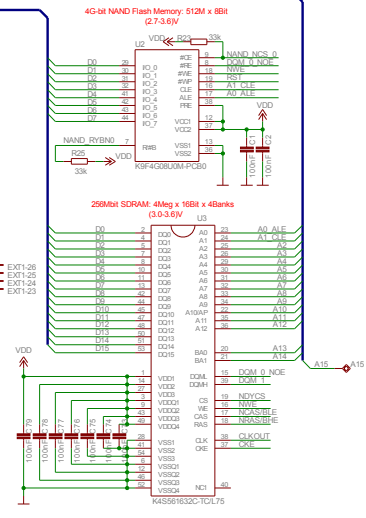
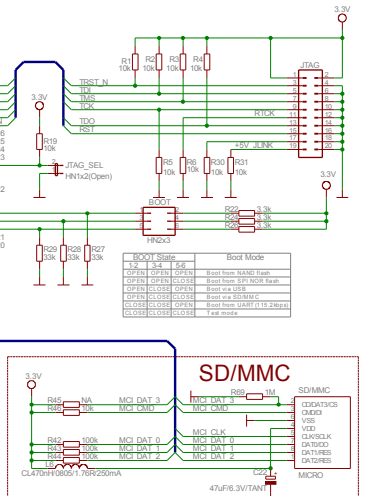
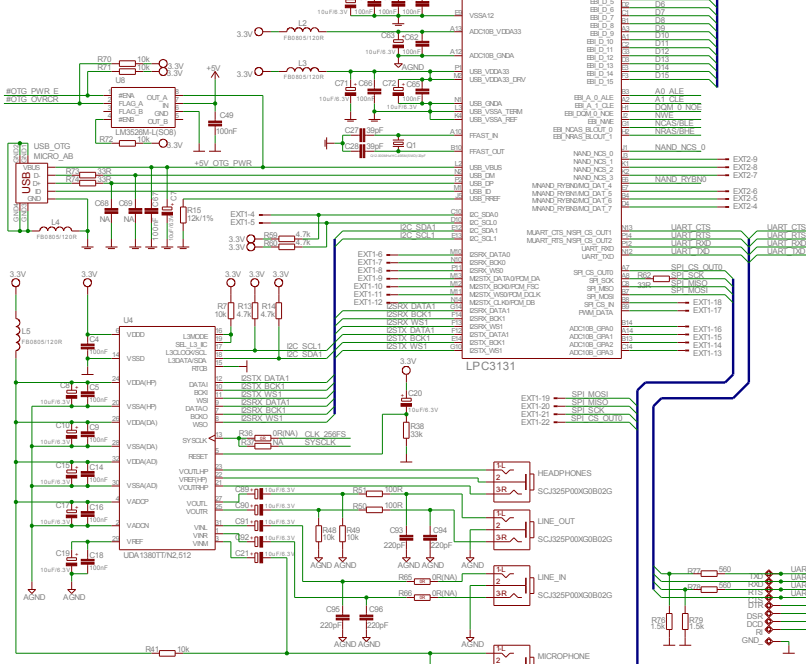

BOARD LAYOUT

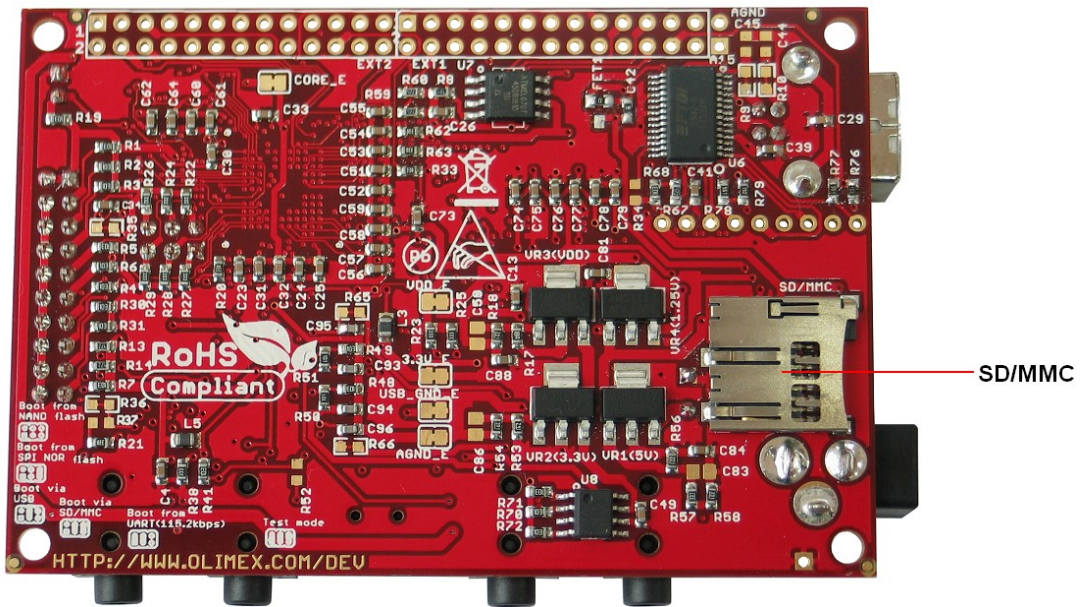
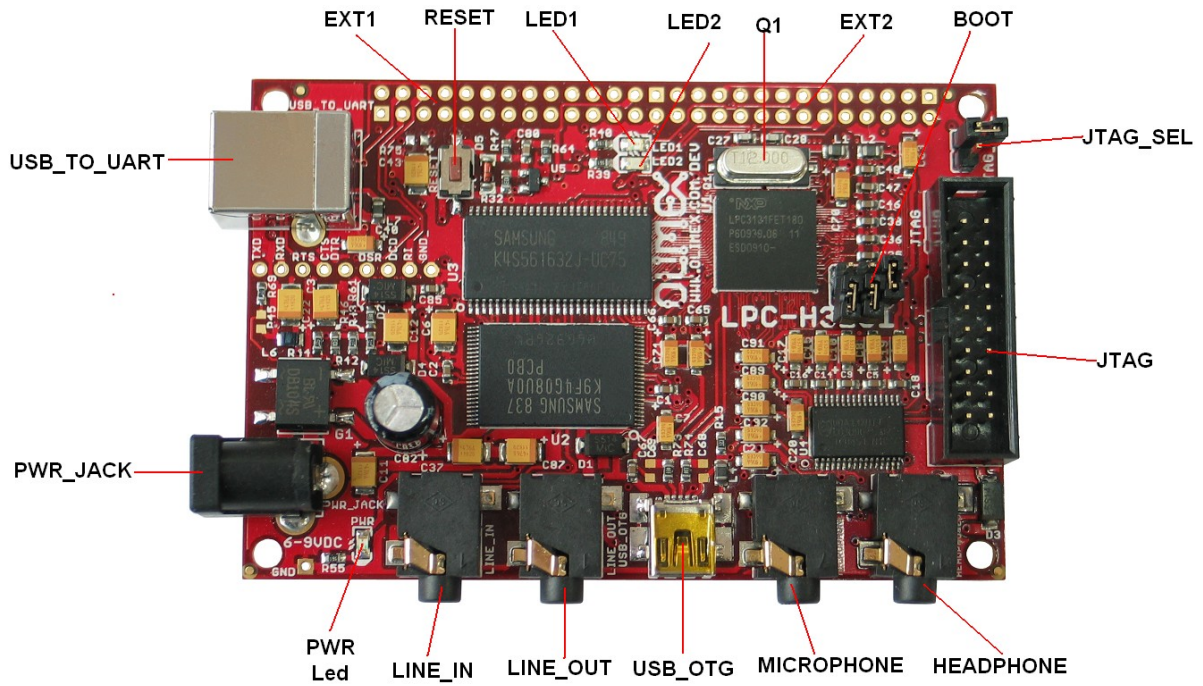

POWER SUPPLY CIRCUIT

LPC-H3131 can take power from four sources:

- External Power Jack - 6V AC, 9V DC
- +5V_OTG_PWR from USB_OTG
- +5V_USB_TO_UART from USB
- +5V_JLINK from JTAG connector

The board power consumption is about 110 mA.

RESET CIRCUIT

LPC-H3131 reset circuit includes JTAG connector pin 15, U2 (NAND Flash) pin 19 (#WP), U7 (SPI-Flash) pin 3 (/RESET/) and pin 5 (/WP/), D5 (1N4148), C80 (100nF), R64 (100 Ohm), R32 (10k), R47 (330 Ohm), LPC3131 pin H14 (RSTIN_N) and Reset button.

CLOCK CIRCUIT

Quartz crystal 12MHz is connected to LPC3131 pin A10 (FFAST_IN) and pin B10 (FFAST_OUT).

JUMPER DESCRIPTION

JTAG_SEL



JTAG selection. Controls output function of SCAN_TDO and ARM_TDO signals.

Default state is open.

BOOT

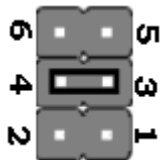

Default state is Boot via USB.

BOOT State			BOOT MODE
1-2	3-4	5-6	
OPEN	OPEN	OPEN	Boot from NAND Flash
OPEN	OPEN	CLOSE	Boot from SPI NOR Flash
OPEN	CLOSE	OPEN	Boot via USB
OPEN	CLOSE	CLOSE	Boot via SD/MMC
CLOSE	CLOSE	OPEN	Boot from UART (115.2kbps)
CLOSE	CLOSE	CLOSE	Test mode

CORE_E



Enables microcontroller core voltage supply.
Default state is closed.

VDD_E



Enables VDD power supply.
Default state is closed.

3.3V_E



Enables board 3.3V power supply.
Default state is closed.

USB_GND_E



Enables USB GND.
Default state is closed.

AGND



Enables board analog GND.
Default state is closed.

INPUT/OUTPUT

User led (yellow) with name **LED1** - connected to LPC3131 pin K12 (GPIO17).

User led (green) with name **LED2** - connected to LPC3131 pin K14 (GPIO18).

Power-on led (red) with name **PWR** - this LED shows that +3.3V is applied to the board.

Reset button with name **RESET** - connected to LPC3131 pin H14 (RSTIN_N).

CONNECTOR DESCRIPTIONS

JTAG

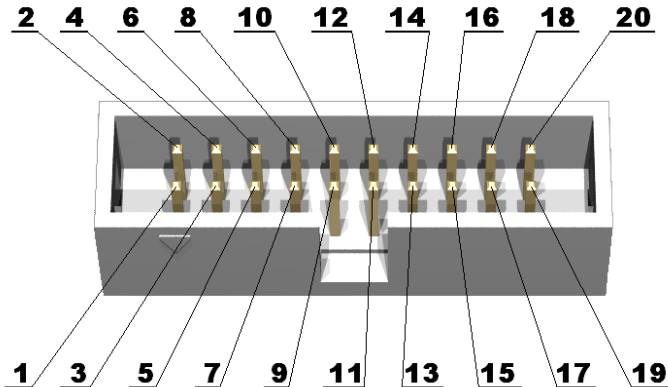

Pin #	Signal Name	Pin #	Signal Name
1	3.3V	2	3.3V
3	TRST_N	4	GND
5	TDI	6	GND
7	TMS	8	GND
9	TCK	10	GND
11	RTCK	12	GND
13	TDO	14	GND
15	RST	16	GND
17	Pull-down	18	GND
19	+5V-JLINK	20	GND

EXT

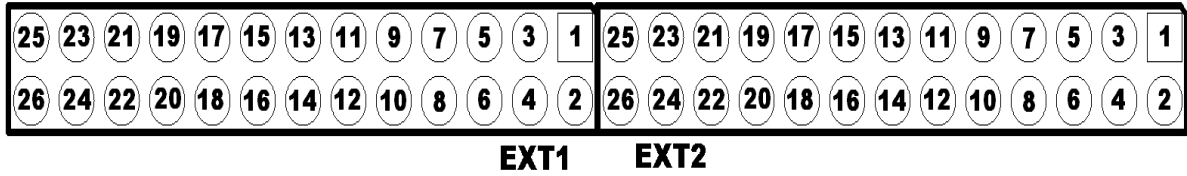

EXT1		EXT2	
Pin#	Signal Name	Pin#	Signal Name
1	3.3V	1	VDD
2	GND	2	GND
3	RST	3	+5V
4	EXT1-4	4	EXT2-4
5	EXT1-5	5	EXT2-5
6	EXT1-6	6	EXT2-6
7	EXT1-7	7	EXT2-7
8	EXT1-8	8	EXT2-8
9	EXT1-9	9	EXT2-9
10	EXT1-10	10	EXT2-10
11	EXT1-11	11	NSTCS_0
12	EXT1-12	12	LED2
13	EXT1-13	13	LED1
14	EXT1-14	14	EXT2-14
15	EXT1-15	15	EXT2-15
16	EXT1-16	16	EXT2-16
17	EXT1-17	17	EXT2-17
18	EXT1-18	18	EXT2-18
19	SPI_MOSI	19	EXT2-19
20	SPI_MISO	20	EXT2-10
21	SPI_SCK	21	EXT2-21
22	SPI_CS_OUT0	22	CLOCK_OUT
23	UART_TXD	23	EXT2-23
24	UART_RXD	24	EXT2-24
25	UART_RTS	25	EXT2-25
26	UART_CTS	26	EXT2-16

USB TO UART

Pin #	Signal Name
1	USB_PWR
2	USBDM
3	USBDP
4	GND

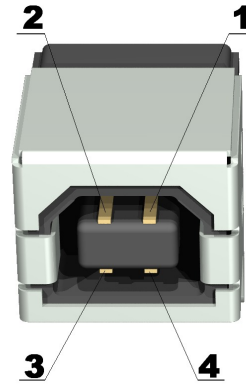

USB OTG

Pin #	Signal Name
1	+5V_OTG_PWR
2	USB_OTG_D-
3	USB_OTG_D+
4	USB_OTG_ID
5	GND

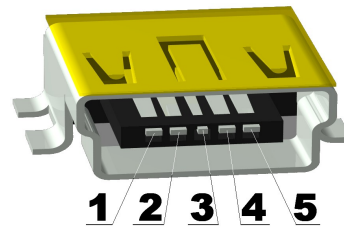

PWR JACK

Pin #	Signal Name
1	Power Input
2	GND

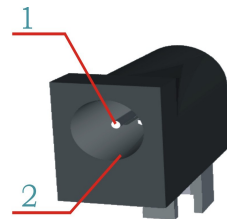

MICROPHONE

Pin #	Signal Name
1	AGND
2	NC
3	MIC

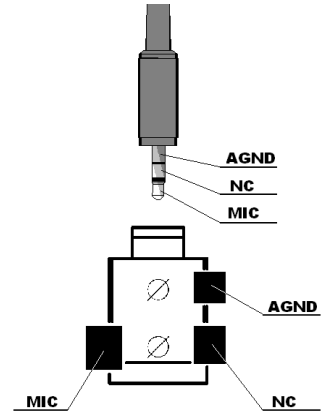

HEADPHONE

Pin #	Signal Name
1	VOUTLHP (left channel)
2	VREF(HP) (common)
3	VOUTRHP (right channel)

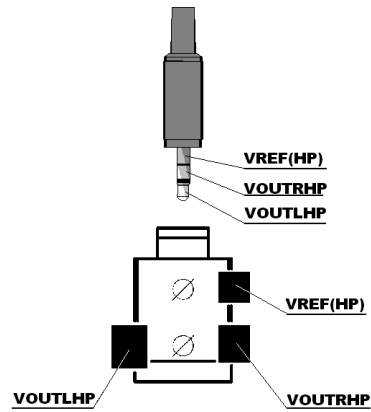

LINE IN

Pin #	Signal Name
1	VINL (left channel)
2	AGND
3	VINR (right channel)

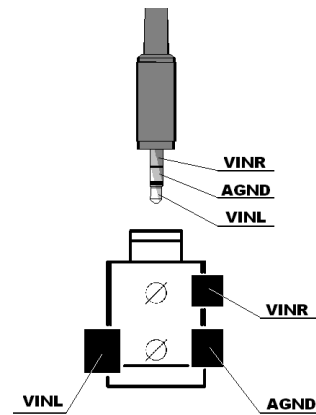

LINE OUT

Pin #	Signal Name
1	VOUTL (left channel)
2	AGND
3	VOUTR (right channel)

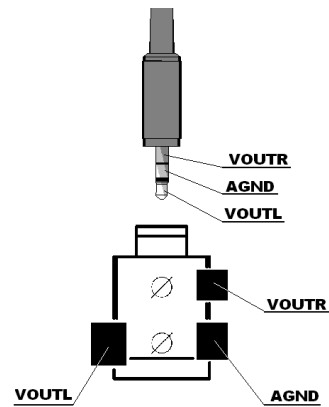

SD/MMC

Pin #	Signal Name
1	MCI_DAT_2
2	MCI_DAT_3
3	MCI_CMD
4	VDD (power supply)
5	MCI_CLK
6	GND
7	MCI_DAT_0
8	MCI_DAT_1
9	Not connected
10	Not connected
11	Not connected
12	Not connected

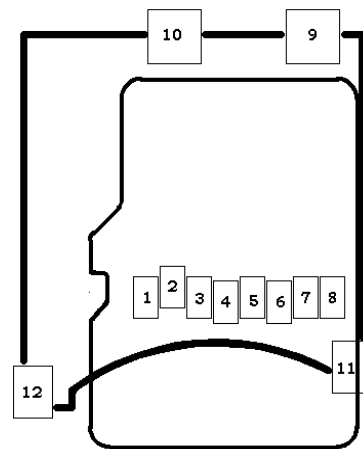

SPI

The SPI module is used for synchronous serial data communication with other devices which support the SPI/SSI protocol. Examples are memories, cameras, or WiFi-g. The SPI/SSI-bus is a 5-wire interface, and it is suitable for low, medium, and high data rate transfers.

This module has the following features:

- Supports Motorola SPI frame format with a word size of 8/16 bits.
- Texas Instruments SSI (Synchronous Serial Interface) frame format with a word size of 4 bit to 16 bit.
- Receive FIFO and transmit FIFO of 64 half-words each.
- Serial clock rate master mode maximum 45 MHz.
- Serial clock rate slave mode maximum 25 MHz.
- Support for single data access DMA.
- Full-duplex operation.
- Supports up to three slaves.
- Supports maskable interrupts.
- Supports DMA transfers.

I²C-bus master/slave interface

The LPC3131 contains two I²C master/slave interfaces.

This module has the following features:

- I²C-bus interface 0 (I²C0): I²C0 is a standard I²C-compliant bus interface with open-drain pins. This interface supports functions described in the I²C-bus specification for speeds up to 400 kHz. This includes multi-master operation and allows powering off this device in a working system while leaving the I²C-bus functional.
- I²C-bus interface 1 (I²C1): I²C1 uses standard I/O pins and is intended for use with a single-master I²C-bus and does not support powering off of this device. Standard I/Os also do not support multi-master I²C implementations.
- Supports normal mode (100 kHz SCL).
- Fast mode (400 kHz SCL with 24 MHz APB clock; 325 kHz with 12 MHz APB clock; 175 kHz with 6 MHz APB clock).
- Interrupt support.
- Supports DMA transfers (single).
- Supports DMA transfers (single).
 - Master transmitter
 - Master receiver
 - Slave transmitter
 - Slave receiver

MECHANICAL DIMENSIONS

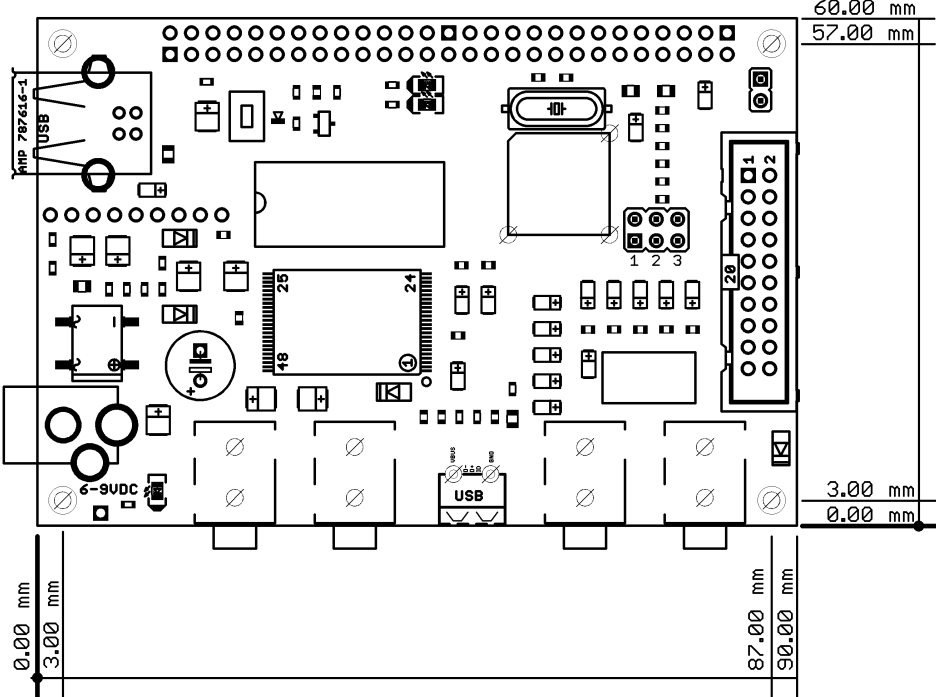

AVAILABLE DEMO SOFTWARE

ORDER CODE

LPC-H3131 - assembled and tested

How to order?

You can order to us directly or by any of our distributors.

Check our web www.olimex.com/dev for more info.

Revision history:

REV. Initial - create May 2010

Disclaimer:

© 2010 Olimex Ltd. All rights reserved. Olimex®, logo and combinations thereof, are registered trademarks of Olimex Ltd. Other terms and product names may be trademarks of others.

The information in this document is provided in connection with Olimex products. No license, express or implied or otherwise, to any intellectual property right is granted by this document or in connection with the sale of Olimex products.

Neither the whole nor any part of the information contained in or the product described in this document may be adapted or reproduced in any material from except with the prior written permission of the copyright holder.

The product described in this document is subject to continuous development and improvements. All particulars of the product and its use contained in this document are given by OLIMEX in good faith. However all warranties implied or expressed including but not limited to implied warranties of merchantability or fitness for purpose are excluded.

This document is intended only to assist the reader in the use of the product. OLIMEX Ltd. shall not be liable for any loss or damage arising from the use of any information in this document or any error or omission in such information or any incorrect use of the product.